

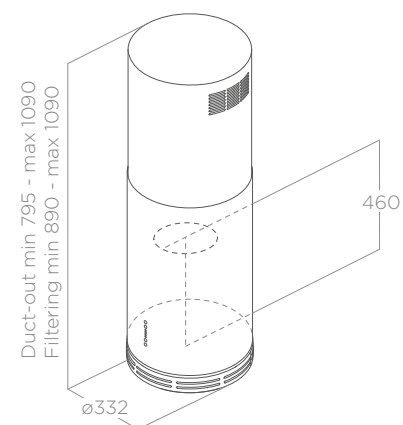

ZENITH

ELICA DESIGN CENTER

Ø33 cm
Duct-out Extraction
Stainless steel
Acier inoxydable



LIGHTING ECLAIRAGE

Type Type	Led 3x2,5 W
Intensity Intensité	571 LUX
Temperature Température	3500 K

PERFORMANCE PERFORMANCE

Controls Commandes	3S+B Electronic push button Touch control 3V+I
Min-max airflow Débit d'air min-max	300 - 800 m ³ /h
Noise level min-max Niveau sonore min-max	49 - 63 db(A)
Total absorption Absorption totale	262 W

Grease aluminium filter included Filtre à graisse en aluminium inclus
Chimney included Cheminée inclus

ACCESSORIES ACCESSOIRES

Charcoal filter Filtre à charbon	CFC0141529A
Regenerable charcoal filter Filtre à charbon régénérable	CFC0141725A

MODELS MODÈLES

ZENITH II IX/A/33	PRF0183060
-------------------	------------

KUADRA ISLAND

ELICA DESIGN CENTER

43x43 - 60x43 cm
Duct-out Extraction
Stainless steel
Acier inoxydable

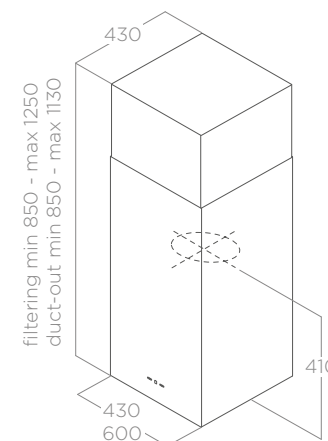

LIGHTING ECLAIRAGE

Type Type	Led 2x2,5 W
Intensity Intensité	457 LUX
Temperature Température	2700 K

PERFORMANCE PERFORMANCE

Controls Commandes	3S+B Electronic push button with display Touch control avec display 3V+I
Min-max airflow Débit d'air min-max	300 - 800 m ³ /h
Noise level min-max Niveau sonore min-max	48 - 62 db(A)
Total absorption Absorption totale	256 W

Grease aluminium filter included Filtre à graisse en aluminium inclus
Chimney included Cheminée inclus

ACCESSORIES ACCESSOIRES

Regenerable charcoal filter Filtre à charbon régénérable	CFC0140423
Island installation extension kit H15 (false ceiling) Kit rallonge installation îlot H15	KIT01600

MODELS MODÈLES

KUADRA ISLAND IX/A/43	PRF0007655A
KUADRA ISLAND IX/A/60	PRF0007028A