

Series 6, heat pump dryer, 10 kg WQK25200ME



Optional accessories

- WMZ20600 : Wool in basket - accessory
- WTZ1110 : Condenser drainage kit
- WTZ27400 : Stacking kit with pull-out shelf
- WTZ27410 : Stacking kit
- WTZPW40D : Platform with pull-out, dryer, cubic

The new Home Connect enabled 10kg tumble dryer with over 15 smart drying programmes, innovative smart dry and additional downloadable features provide ultimate fabric care and perfect drying results that keep your dryer always updated.

- The Bosch heat pump dryer is America's most efficient dryer in its class.
- Ventless condensation drying eliminates the need for ducting
- The QuickDry Auto program is perfect for activewear and gently, yet quickly dries clothes.
- **Easy Clean with A++:** dries very efficient. With easy cleaning of the condenser filter.
- The EcoSilence™ Motor is energy efficient and quiet in operation with an especially long life.

Technical Data

- Built-in / Free-standing : Free-standing
- Removable top : No
- Door hinge : Right
- Color / Material body : White
- Length electrical supply cord : 145 cm
- Dimensions : 842x598x613 mm
- Net weight : 49.5 kg
- Drum volume : 112 l
- Fluorinated greenhouse gases : R290
- Hermetically sealed equipment : Yes
- Connection rating : 600 W
- Fuse protection : 10 A
- Voltage : 220-240 V
- Frequency : 50 Hz
- Drying process : automatic
- Maximum capacity in kg : 10.0 kg



Series 6, heat pump dryer, 10 kg WQK25200ME

The new Home Connect enabled 10kg tumble dryer with over 15 smart drying programmes, innovative smart dry and additional downloadable features provide ultimate fabric care and perfect drying results that keep your dryer always updated.

- Tumble Dryer with Heat Pump

Engine Power and Consumption

- Energy Efficiency Class¹: A++
- Energy²: 282 kWh
- Capacity: 1 - 10 kg
- Programme time³: 270 min
- Noise level: 63 dB (A) re 1 pW
- Condensation efficiency class⁴: B
- Condensation efficiency⁵: 83 %

Programmes

- standard programmes: cotton, easy care
- programmes via app: Woollens finish
- Special programmes: App, Cotton, Shirts/blouses, Cotton Eco, Down wear, Delicates, Towels, Mixed Load, Super Quick 40 minutes program, Sportswear, Duvet, Synthetic, Timed Program Cold, Timed Program Warm

Options

- Home Connect: Smart Start, Remote Monitoring and Control, Smart Dry, Remote Diagnostics, Onboarding, Programme Assistant, further programmes via download, Always keep your appliance up to date via firmware update.
- SmartDry: Perfect drying programme based on last washing cycle
- Half Load option: optimizes drying for smaller loads
- Anti crease cycle 120 min at the end of the programme
- Touch control buttons: basic setup, end time delay, Half load, less ironing, Remote Start, Low Heat, SmartDry, Start / Reload / Pause, drying aim, end time delay

comfort and safety

- EasyClean filter
- Elegant and ergonomically inclined control panel for easy use
- Large LED-Display for remaining time and 24 h end time delay, programme status indication, special functions.
- load recommendation
- reload indication
- AutoDry technology
- control dial
- Sensitive Drying System: Big Stainless steel drum with textile care structure, soft design paddles
- AntiVibration Design: more stability and quietness
- Drain Set
- Child-proof lock
- Buzzer to indicate the end of cycle
- Usage meter: counts completed programmes
- Metal door closing hook

Technical Information

- Slide-under height of 85cm
- Dimensions (H x W x D): 84.2 cm x 59.8 cm x 61.3 cm
- Dimensions (H x W): 84.2 cm x 59.8 cm
- Appliance depth: 61.3 cm
- Appliance depth incl. door: 64.8 cm
- Appliance depth with open door: 109.6 cm

¹ At a range of energy efficiency classes from A+++ to D
² Energy consumption kWh per year, based on 160 drying cycles of the standard cotton programme at full and partial load, and the consumption of the low power modes

³ Programme time of the standard cotton programme at full load

⁴ On a condensation efficiency class scale from A to G

⁵ Weighted condensation efficiency for the standard cotton programme at full and partial load

**Series 6, heat pump dryer, 10 kg
WQK25200ME**

Measurements in mm

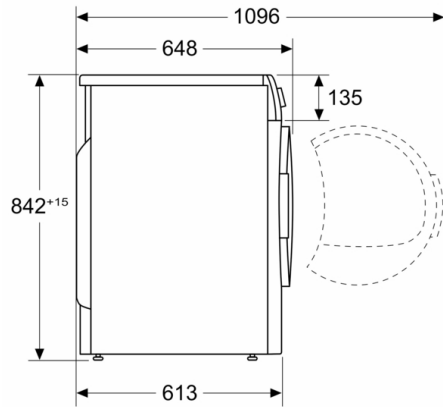

Measurements in mm

