

MOON ISLAND

ELICA DESIGN CENTER

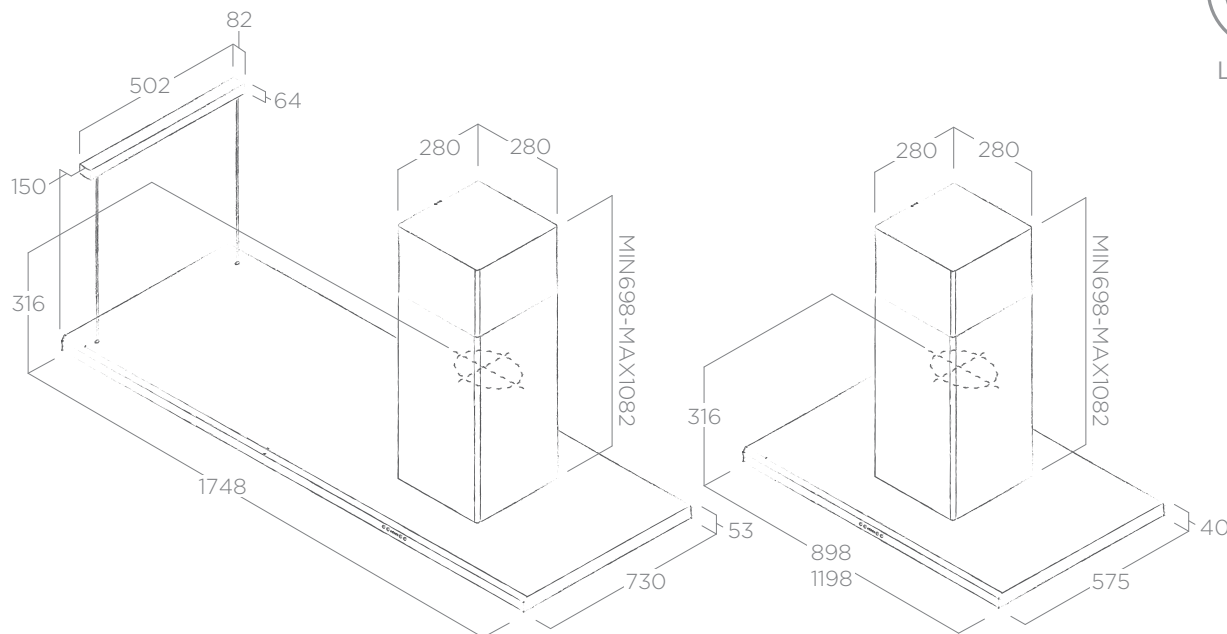

LONG LIFE FILTER



CM 50



CM 65

WALL VERSION P. 84

VERSION MURALE P. 84

TECHNICAL FEATURES INFORMATIONS TECHNIQUES

Size Dimensions	90x57 - 120x57 - 175x73 cm
Version Version	Duct-out Extraction - Filtering Recyclage (180cm)
Finish Finition	Stainless steel Acier inox

LIGHTING ECLAIRAGE

Type Type	Neon 2x21W (90cm) 2X28W (120cm) 4x21W (180cm)
Intensity Intensité	210 (90cm) - 280 (120cm) - 252 (180cm) LUX
Temperature Température	6500 K

PERFORMANCE PERFORMANCE

Controls Commandes	3S+B Touch Control Commandes Tactiles 3V+I
Min-max airflow Aspiration min-max	350 - 900 m ³ /h
Min-Max noise level Niveau sonore min-max	52 - 69 db(A)
Total absorption Absorption totale	302 (90cm) - 316 (120cm) - 344 (180cm) W
Duct size Sortie	150 mm

Grease aluminium filter included Filtre à graisse en aluminium inclus
Charcoal filter included Filtre à charbon inclus (*)

ACCESSORIES ACCESSOIRES

Charcoal Filter Filtre à charbon	CFC0141529
Long Life Filter Filtre longue durée	CFC0141725

MODELS MODELES

MOON IS IX/A/60X90	PRF0093507A
MOON IS IX/A/60X120	PRF0093541A
MOON ISLAND IX/F/180 (*)	PRF0079552A



