

KREA

ELICA DESIGN CENTER



TECHNICAL FEATURES INFORMATIONS TECHNIQUES

Size Dimensions	60 - 70 - 90 cm
Version Version	Recycling Recyclage
Finish Finition	Stainless steel, white, black Acier inox, blanc, noir

ECLAIRAGE LIGHTING

	STD	GFA	LUX
Type Type	LED 1 x 3 W	LED 2 x 3 W	LED 2 x 3 W
Intensity Intensité	42 LUX	85 LUX	85 LUX
Temperature Température	2700 K	2700 K	2700 K

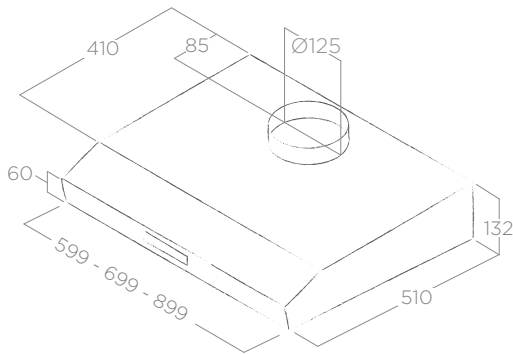

PERFORMANCE PERFORMANCE

	STD	GFA	LX
Controls Commandes	3S Slider Curseur 3V	3S Slider Curseur 3V	3S Slider Curseur 3V
Min - max airflow Débit d'air min - max	150-350 m³/h	150-350 m³/h	250-450 m³/h
Min - max noise level Niveau sonore min - max	52-71 db(A)	52-71 db(A)	52-73 db(A)
Total absorption Absorption totale	118 W	121 W	166 W
Duct size Sortie	120 mm	120 mm	120 mm
Grease aluminium Filter included Filtre à graisse en aluminium inclus	Charcoal filter included Filtre charbon longue durée inclus		

ACCESSORIES ACCESSOIRES

Charcoal Filter Filtre à charbon	CFC0140064
----------------------------------	------------

MODELS MODÈLES

KREA ST IX F/60	55311065B
KREA ST IX F/90	55311075B
KREA GFA WH/F/60	55310774B
KREA GFA WH/F/90	PRF0104636B
KREA GFA BL/F/60	PRF0104634B
KREA GFA BL/F/90	PRF0104635B
KREA LX IX F/60	55311112A
KREA LX IX F/70	PRF0156131
KREA LX IX F/90	55311129A
KREA LX WH F/60	PRF0154685
KREA LX WH F/90	PRF0154739
KREA LX BL F/60	PRF0154690
KREA LX BL F/70	PRF0156135
KREA LX BL F/90	PRF0154726



BUILT-IN