



**BOSCH**



**Register** your  
new appliance  
now at MyBosch and  
enjoy benefits free of  
charge:  
[bosch-home.com/  
welcome](https://bosch-home.com/welcome)

# Fridge-freezer combination

**KFN96...**

**[en]** Information for Use



**You can find additional information and explanations online.  
Scan the QR code on the title page.**



## Table of contents

<b>1 Safety</b> .....	<b>3</b>	<b>7 Basic operation</b> .....	<b>15</b>
1.1 Definition of the signal words .....	3	7.1 Switching on the appliance .....	15
1.2 General information .....	3	7.2 Operating tips .....	15
1.3 Intended use .....	4	7.3 Switching off the appliance .....	15
1.4 Restriction on user group .....	4	7.4 Setting the temperature .....	15
1.5 Safe transport .....	4	7.5 Keylock .....	16
1.6 Safe installation .....	4	<b>8 Additional functions</b> .....	<b>16</b>
1.7 Safe use .....	5	8.1 Super cooling .....	16
1.8 Damaged appliance .....	7	8.2 Super freezing .....	16
<b>2 Preventing material damage</b> .....	<b>8</b>	8.3 Energy-saving mode .....	16
<b>3 Environmental protection and saving energy</b> .....	<b>8</b>	8.4 Rest mode .....	17
3.1 Disposing of packaging .....	8	<b>9 Alarm</b> .....	<b>17</b>
3.2 Saving energy .....	9	9.1 Door alarm .....	17
<b>4 Installation and connection</b> .....	<b>9</b>	9.2 Temperature alarm .....	17
4.1 Scope of delivery .....	9	<b>10 Refrigerator compartment</b> .....	<b>18</b>
4.2 Criteria for the installation location .....	9	10.1 Tips for storing food in the refrigerator compartment .....	18
4.3 Installing the appliance .....	10	10.2 Chill zones in the refrigerator compartment .....	18
4.4 Preparing the appliance for the first time .....	10	<b>11 Freezer compartment</b> .....	<b>18</b>
4.5 Connecting the appliance to the electricity supply .....	10	11.1 Freezing capacity .....	18
<b>5 Familiarising yourself with your appliance</b> .....	<b>11</b>	11.2 Fully utilising the freezer compartment volume .....	19
5.1 Appliance .....	11	11.3 Tips for storing food in the freezer compartment .....	19
5.2 Control panel .....	12	11.4 Tips for freezing fresh food ...	19
<b>6 Features</b> .....	<b>13</b>	11.5 Shelf life of frozen food at -18 °C .....	19
6.1 Shelf .....	13	11.6 Defrosting methods for frozen food .....	19
6.2 Storage container .....	13	<b>12 Defrosting</b> .....	<b>20</b>
6.3 Fruit and vegetable container with humidity control .....	14	12.1 Defrosting in the refrigerator compartment .....	20
6.4 Butter and cheese compartment .....	14	12.2 Defrosting in the freezer compartment .....	20
6.5 Door tray .....	14	<b>13 Cleaning and servicing</b> .....	<b>20</b>
6.6 Accessories .....	14		

13.1 Preparing the appliance for cleaning .....	20	<b>15 Storage and disposal .....</b>	<b>26</b>
13.2 Cleaning the appliance .....	20	15.1 Taking the appliance out of operation .....	26
13.3 Removing the fittings .....	21	15.2 Disposing of old appliance ...	26
13.4 Removing appliance components .....	22	<b>16 Customer Service .....</b>	<b>27</b>
<b>14 Troubleshooting .....</b>	<b>23</b>	16.1 Product number (E-Nr.) and production number (FD) .....	27
14.1 Power failure .....	25	<b>17 Technical data .....</b>	<b>28</b>
14.2 Conducting an appliance self-test .....	26		

## 1 Safety

Observe the following safety instructions.

### 1.1 Definition of the signal words

This is where you can find explanations for the safety signal words used in this manual.

#### **WARNING**

This indicates that death or serious injuries may occur as a result of non-observance of this warning.

#### **CAUTION**

This indicates that minor or moderate injuries may occur as a result of non-observance of this warning.

#### **ATTENTION**

This indicates that damage to the appliance or other material damage may occur as a result of non-compliance with this warning.

**Note:** This alerts you to important information.

### 1.2 General information

- Read this instruction manual carefully.
- Keep the instruction manual and the product information safe for future reference or for the next owner.
- Do not connect the appliance if it has been damaged in transit.

### 1.3 Intended use

Only use this appliance:

- for chilling and freezing food and for making ice cubes.
- in private households and in enclosed spaces in a domestic environment.
- Up to an altitude of 2000 m above sea level.

### 1.4 Restriction on user group

This appliance may be used by children aged 8 or over and by people who have reduced physical, sensory or mental abilities or inadequate experience and/or knowledge, provided that they are supervised or have been instructed on how to use the appliance safely and have understood the resulting dangers.

Do not let children play with the appliance.

Cleaning and user maintenance must not be performed by children unless they are being supervised.

Children above the age of three years old and younger than eight years old may load and unload the refrigerating appliance.

### 1.5 Safe transport

#### **WARNING – Risk of injury!**

The heavy weight of the appliance may result in injury when lifted.

- ▶ Do not lift the appliance on your own.

### 1.6 Safe installation

#### **WARNING – Risk of electric shock!**

Incorrect installation is dangerous.

- ▶ Connect and operate the appliance only in accordance with the specifications on the rating plate.
- ▶ Connect the appliance to a power supply with alternating current only via a properly installed socket with earthing.
- ▶ The protective conductor system of the domestic electrical installation must be properly installed.
- ▶ Never equip the appliance with an external switching device, e.g. a timer or remote control.
- ▶ When the appliance is installed, the mains plug of the power cord must be freely accessible. If free access is not possible, an

isolating switch must be integrated into the permanent electrical installation according to the installation regulations.

- ▶ When installing the appliance, check that the power cable is not trapped or damaged.

If the insulation of the power cord is damaged, this is dangerous.

- ▶ Never let the power cord come into contact with heat sources.

### **⚠ WARNING – Risk of explosion!**

If the appliance's ventilation openings are closed off, a leak in the refrigeration circuit may result in a flammable mixture of gas and air.

- ▶ Keep ventilation openings in the appliance casing or in the integrated casing clear of obstruction.

### **⚠ WARNING – Risk of fire!**

It is dangerous to use an extended power cord and non-approved adapters.

- ▶ Do not use extension cables or multiple socket strips.
- ▶ Only use adapters and power cords approved by the manufacturer.
- ▶ If the power cord is too short and a longer one is not available, please contact an electrician to have the domestic installation adapted.

Portable multiple socket strips or portable power supply units may overheat and cause a fire.

- ▶ Do not place portable multiple socket strips or power supply units on the back of the appliance.

## **1.7 Safe use**

### **⚠ WARNING – Risk of electric shock!**

An ingress of moisture can cause an electric shock.

- ▶ Only use the appliance in enclosed spaces.
- ▶ Never expose the appliance to intense heat or humidity.
- ▶ Do not use steam- or high-pressure cleaners to clean the appliance.

### **⚠ WARNING – Risk of suffocation!**

Children may put packaging material over their heads or wrap themselves up in it and suffocate.

- ▶ Keep packaging material away from children.

▶ Do not let children play with packaging material. Children may breathe in or swallow small parts, causing them to suffocate.

- ▶ Keep small parts away from children.
- ▶ Do not let children play with small parts.

**⚠ WARNING – Risk of explosion!**

If the cooling circuit is damaged, flammable refrigerant may escape and explode.

- ▶ To accelerate the defrosting process, do not use any other mechanical devices or means other than those recommended by the manufacturer.
- ▶ If food is stuck to the freezer compartment, loosen it with a blunt object such as the handle of a wooden spoon.

Products which contain flammable propellants and explosive substances may explode, e.g. spray cans.

- ▶ Do not store products which contain flammable propellants (e.g. spray cans) or explosive substances in the appliance.

**⚠ WARNING – Risk of fire!**

Electrical devices within the appliance may cause a fire, e.g. heaters or electric ice makers.

- ▶ Do not operate electrical devices within the appliance.

**⚠ WARNING – Risk of injury!**

Containers that contain carbonated drinks may burst.

- ▶ Do not store containers that contain carbonated drinks in the freezer compartment.

Injury to the eyes caused by escaping flammable refrigerant and hazardous gases.

- ▶ Do not damage the tubes of the refrigerant circuit or the insulation.

The appliance may tip.

- ▶ Do not stand or support yourself on the base, runners or doors.

**⚠ WARNING – Risk of cold burns!**

Contact with frozen food and cold surfaces may cause burns by refrigeration.

- ▶ Never put frozen food straight from the freezer compartment into your mouth.

- ▶ Avoid prolonged contact of the skin with frozen food, ice and surfaces in the freezer compartment.

### **⚠ CAUTION – Risk of harm to health!**

To prevent food from being contaminated, you must observe the following instructions.

- ▶ If the door is open for an extended period of time, this may lead to a considerable temperature increase in the compartments of the appliance.
- ▶ Regularly clean the surfaces that may come into contact with food and accessible drain systems.
- ▶ Store raw meat and fish in suitable containers in the refrigerating appliance so that they do not touch or drip on other food.
- ▶ If the fridge/freezer is empty for an extended period of time, switch off the appliance, defrost it, clean it and leave the door open to prevent the formation of mould.

Metal or metal-style parts in the appliance may contain aluminium. If acidic food comes into contact with aluminium in the appliance, aluminium foil ions may pass into the food.

- ▶ Do not consume soiled food.

## **1.8 Damaged appliance**

### **⚠ WARNING – Risk of electric shock!**

If the appliance or the power cord is damaged, this is dangerous.

- ▶ Never operate a damaged appliance.
- ▶ Never pull on the power cord to unplug the appliance. Always unplug the appliance at the mains.
- ▶ If the appliance or the power cord is damaged, immediately unplug the power cord or switch off the fuse in the fuse box.
- ▶ Call customer service. → *Page 27*

Improper repairs are dangerous.

- ▶ Repairs to the appliance should only be carried out by trained specialist staff.
- ▶ Only use genuine spare parts when repairing the appliance.
- ▶ If the power cord or the appliance power cable of this appliance is damaged, it must be replaced with a special power cord or special appliance power cable, which is available from the manufacturer or its Customer Service.

**⚠ WARNING – Risk of fire!**



If the tubes are damaged, flammable refrigerant and harmful gases may escape and ignite.

- ▶ Keep naked flames and ignition sources away from the appliance.
- ▶ Ventilate the room.
- ▶ Switch off the appliance. → *Page 15*
- ▶ Unplug the mains plug from the mains or switch off the circuit breaker in the fuse box.
- ▶ Call customer service. → *Page 27*

---

## 2 Preventing material damage

### ATTENTION

The high weight of the appliance or, if not rolling freely, the appliance's castors may damage the floor when the appliance is moved.

- ▶ Transport the appliance using a sack truck.
- ▶ Use floor protection when moving the appliance, and do not move it in a zigzag fashion.

When the appliance door is closed, an open door pillar may damage the appliance.

- ▶ Never open the door pillar manually.
- ▶ If the door pillar has been opened, close it before closing the appliance door.

Using the appliance, base, runners or doors as a seat or climbing surface may damage the appliance.

- ▶ Do not stand or lean on the appliance, base, runners or doors.

Contamination with oil or fat may cause plastic parts and door seals to become porous.

- ▶ Keep plastic parts and door seals free of oil and grease.

Metal or metal-style parts in the appliance may contain aluminium. When aluminium comes into contact with acidic foods, it corrodes and discolours.

- ▶ Only store packaged food in the appliance.

If you clean fittings and accessories in the dishwasher, this may cause them to become deformed or discoloured.

- ▶ Never clean fittings and accessory in the dishwasher.

---

## 3 Environmental protection and saving energy

### 3.1 Disposing of packaging

The packaging materials are environmentally compatible and can be recycled.

- ▶ Sort the individual components by type and dispose of them separately.

### 3.2 Saving energy

If you follow these instructions, your appliance will use less power.

#### Selecting the installation location

- Keep the appliance out of direct sunlight.
- Install the appliance as far away as possible from heating elements, cookers and other heat sources:
  - Maintain a 30 mm clearance to electric or gas cookers.
  - Maintain a 300 mm clearance to oil or solid-fuel cookers.
- Never cover or block the external ventilation openings.

#### Saving energy during use

**Note:** The arrangement of the fittings does not affect the energy consumption of the appliance.

- Open the appliance only briefly and then close it carefully.
- Never cover or block the interior ventilation openings or the exterior ventilation openings.
- Transport purchased food in a cool bag and place in the appliance quickly.
- Allow warm food and drinks to cool down before storing them.
- Thaw frozen food in the refrigerator compartment to utilise the low temperature of the food.
- Always leave some space between the food and to the back panel.
- Vacuum the external ventilation grilles when they are dusty.

## 4 Installation and connection

### 4.1 Scope of delivery

After unpacking all parts, check for any transport damage and for completeness of delivery.

If you have any complaints, contact your dealer or our after-sales service → *Page 27*.

The delivery consists of the following:

- Free-standing appliance
- Equipment and accessories<sup>1</sup>
- Installation material
- Installation instructions
- User manual
- Customer service directory
- Warranty enclosure<sup>2</sup>
- Energy label
- Information on energy consumption and noises

### 4.2 Criteria for the installation location

#### **WARNING**

#### **Risk of explosion!**

If the appliance is in a space that is too small, a leak in the refrigeration circuit may result in a flammable mixture of gas and air.

- ▶ Only install the appliance in a space with a volume of at least 1 m<sup>3</sup> per 8 g refrigerant. The volume of refrigerant is indicated on the rating plate.

→ "Appliance", Fig. **1**/**4**  
*Page 12*

The weight of the appliance ex works may be up to 165 kg depending on the model.

<sup>1</sup> Depending on the appliance specifications

<sup>2</sup> Not in all countries

The subfloor must be sufficiently stable to bear the weight of the appliance.

The surface must be level.

This refrigerator is intended for use at ambient temperatures of 10 °C to 43 °C.

The appliance is fully functional within the permitted room temperature.

If the appliance is operated at colder room temperatures, the appliance will not be damaged up to a room temperature of 5 °C.

### **Over-and-under and side-by-side installation**

If you want to install 2 refrigerating appliances one over the other or side by side, you must maintain a clearance of at least 150 mm between the appliances. Selected appliances can be installed without a minimum clearance. Ask your dealer or kitchen planner about this.

### **4.3 Installing the appliance**

- ▶ Install the appliance in accordance with the enclosed installation instructions.

### **4.4 Preparing the appliance for the first time**

1. Remove the informative material.
2. Remove the protective foil and transit bolts, e.g. remove the adhesive strips and carton.
3. Clean the appliance for the first time. → *Page 20*

### **4.5 Connecting the appliance to the electricity supply**

1. Insert the appliance plug of the power cord into the appliance.
2. Insert the mains plug of the appliance's power cable in a socket nearby.

The connection data of the appliance can be found on the rating plate.

→ "Appliance", Fig. **1/4**  
*Page 12*

3. Check the mains plug is inserted properly.
- ✓ The appliance is now ready for use.

## 5 Familiarising yourself with your appliance

### 5.1 Appliance

You can find an overview of the parts of your appliance here.

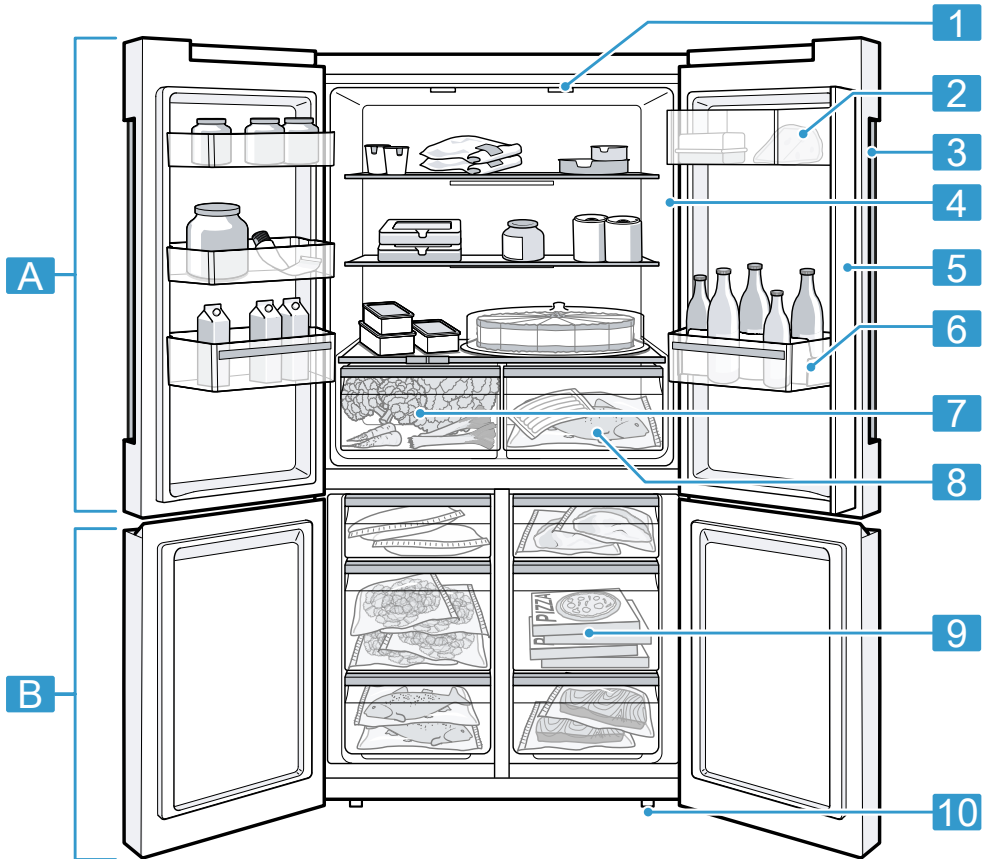

**1**

Deviations between your appliance and the diagrams may differ with regard to their features and size.

**A** Refrigerator compartment  
→ Page 18

**B** Freezer compartment  
→ Page 18

**1** Lighting

**2** Butter and cheese compartment  
→ Page 14

---

**3** Control panel → *Page 12*

---

**4** Rating plate → *Page 28*

---

**5** Door pillar with condensation protection → *Page 8*

---

**6** Door tray for large bottles  
→ *Page 14*

---

---

**7** Fruit and vegetable container with humidity control  
→ *Page 14*

---

**8** Storage container → *Page 13*

---

**9** Frozen food container  
→ *Page 22*

---

**10** Screw foot

---

## 5.2 Control panel

You can use the control panel to configure all functions of your appliance

and to obtain information about the operating status.

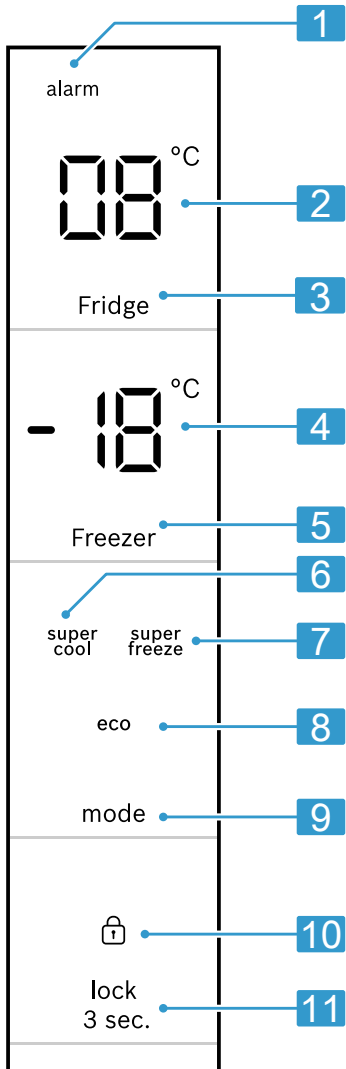
**2**

- 1** alarm lights up when the alarm is switched on.

- 2** Displays the set temperature for the refrigerator compartment in °C.
- 3** Fridge sets the temperature of the refrigerator compartment.
- 4** Displays the set temperature for the freezer compartment in °C.
- 5** Freezer sets the temperature of the freezer compartment.
- 6** super cool lights up when Super cooling is switched on.
- 7** super freeze lights up when Super freezing is switched on.
- 8** eco lights up when the energy-saving mode is switched on.
- 9** mode is used to select an additional function.
- 10** lock icon lights up when the keylock is activated.
- 11** lock 3 sec. switches the keylock for the control panel on or off.

## 6 Features

The features of your appliance depend on the model.

### 6.1 Shelf

To vary the shelf as required, you can remove the shelf and re-insert it elsewhere.

→ "Removing the shelf", Page 21

### 6.2 Storage container

The temperatures in the storage container are lower than in the refrigerator compartment. Temperatures below 0 °C may occur occasionally. In order to reach temperatures close to 0 °C in the storage container, set the refrigerator compartment temperature to 2 °C. → Page 15

Use the lower temperatures in the storage container to store highly perishable food, e.g. fish, meat and sausages.

### 6.3 Fruit and vegetable container with humidity control

Store fresh fruit and vegetables loose in the fruit and vegetable container. Cover any chopped fruit and vegetables, or store in air-tight packaging. You can adjust the humidity in the fruit and vegetable container using the humidity controller. This allows fresh fruit and vegetables to be stored for longer than with conventional storage.

The air humidity in the fruit and vegetable container can be set according to the type and amount of food to be stored by moving the humidity controller:

- Move to the left for low humidity ♠ when primarily storing fruit or mixed items, or if the appliance is very full.
- Move to the right for high humidity 🌿 🌿 when primarily storing vegetables or when the appliance is not very full.

Condensation may form in the fruit and vegetable container depending on the food and quantity stored. Remove the condensation with a dry cloth and adjust the air humidity to a lower setting using the humidity controller.

To ensure that the quality and aroma are retained, store fruit and vegetables that are sensitive to cold outside of the appliance at temperatures of approx. 8 °C to 12 °C, e.g. pineapple, bananas, citrus fruits, cucumbers, courgettes, peppers, tomatoes and potatoes.

### 6.4 Butter and cheese compartment

Store butter and hard cheese in the butter and cheese compartment.

### 6.5 Door tray

To adjust the door tray as required, you can remove the door tray and re-insert elsewhere.

→ "Removing door tray", Page 21

### 6.6 Accessories

Use original accessories. These have been made especially for your appliance.

The accessories for your appliance depend on the model.

#### Egg tray

Store eggs safely on the egg tray.

#### Bottle holder

The bottle holder prevents bottles from falling over when the appliance door is opened and closed.

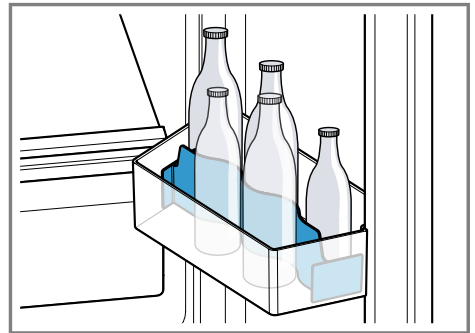

#### Ice cube tray

Use the ice cube tray to make ice cubes.

#### Making ice cubes

Use only drinking water to make ice cubes.

1. Fill the ice cube tray with drinking water up to  $\frac{3}{4}$  and place in the freezer compartment.  
If the ice cube tray is stuck to the freezer compartment, loosen it with a blunt object such as the handle of a wooden spoon.
2. To loosen the ice cubes, twist the ice cube tray slightly or hold it briefly under flowing water.

---

## 7 Basic operation

### 7.1 Switching on the appliance

1. Electrically connect the appliance.  
→ *Page 10*
- ✓ The appliance is now ready for use.
- ✓ The appliance begins to cool.
- ✓ A warning signal sounds, the temperature display (freezer compartment) flashes and "alarm" lights up because the freezer compartment is still too warm.
2. Switch off the warning tone using **alarm**.
- ✓ "alarm" goes out as soon as the set temperature has been reached.
3. Set the required temperature.  
→ *Page 15*

### 7.2 Operating tips

- Once you have switched on the appliance, the set temperature is only reached after several hours. Do not put any food in the appliance until the set temperature has been reached.
- The front and side panels of the housing heat up occasionally. This prevents condensation from forming.
- When closing the door, make sure that the door is not blocked by stored items.

- When you close the door, a vacuum may be created. The door is then difficult to open again. Wait a moment until the vacuum is offset.
- The temperature in the appliance varies due to the following conditions:
  - How often the appliance is opened
  - Load capacity
  - Temperature of newly stored food
  - Ambient temperature
  - Direct sunlight

### 7.3 Switching off the appliance

- ▶ Disconnect the appliance from the power supply. Unplug the appliance from the mains or switch off the circuit breaker in the fuse box.

### 7.4 Setting the temperature

#### Setting the refrigerator compartment temperature

- ▶ Press **Fridge** repeatedly until the temperature display (refrigerator compartment) shows the required temperature setting.  
The recommended temperature in the refrigerator compartment is 4 °C.

#### Setting the freezer compartment temperature

- ▶ Press **Freezer** repeatedly until the temperature display (freezer compartment) shows the required temperature setting.  
The recommended temperature in the freezer compartment is -18 °C.

## 7.5 Keylock

The keylock prevents the appliance from being operated accidentally or incorrectly while running.

### Switching on the keylock

- ▶ Press and hold **lock 3 sec.** for three seconds.
- ✓  lights up.

### Switching off the keylock

- ▶ Press and hold **lock 3 sec.** for three seconds.
- ✓  goes out.

---

## 8 Additional functions

Find out which additional functions can be used for your appliance.

### 8.1 Super cooling

With Super cooling, the refrigerator compartment cools as cold as possible.

Switch on Super cooling before placing large quantities of food in the refrigerator compartment.

**Note:** When Super cooling is switched on, increased noise may occur.

#### Switching on Super cooling

- ▶ Press **mode** repeatedly until "super cool" lights up.
- ✓ "SU" lights up in the temperature display (refrigerator compartment).

**Note:** After approx. 6 hours, the appliance switches to normal operation.

#### Switching off Super cooling

- ▶ Press **mode** repeatedly until "super cool" goes out.
- ✓ The previously set temperature is displayed.

### 8.2 Super freezing

With Super freezing, the freezer compartment cools as cold as possible. Switch on Super freezing one to two hours before placing food weighing 2 kg or more into the freezer compartment.

In order to utilise the freezer capacity, use Super freezing.

→ *"Prerequisites for freezing capacity", Page 19*

**Note:** When Super freezing is switched on, increased noise may occur.

#### Switching on Super freezing

- ▶ Press **mode** repeatedly until "super freeze" lights up.
- ✓ "SU" lights up on the temperature display (freezer compartment).

**Note:** After approx. 54 hours, the appliance switches to normal operation.

#### Switching off Super freezing

- ▶ Press **mode** repeatedly until "super freeze" goes out.
- ✓ The previously set temperature is displayed.

### 8.3 Energy-saving mode

You can set the appliance to save energy with the energy-saving mode. The appliance automatically sets the temperatures.

---

Refrigerator com- 8 °C  
partment

---

Freezer compart- -16 °C  
ment

---

#### Switching on energy-saving mode

- ▶ Press **mode** repeatedly until "eco" lights up.

## Switching off energy-saving mode

- ▶ Press **mode** repeatedly until "eco" goes out.
- ✓ The previously set temperature is displayed.

## 8.4 Rest mode

The rest mode switches off all non-essential functions.

During rest mode, the following functions are switched off:

- Super cooling
- Super freezing
- Alarm
- Interior lighting
- Signal tones
- Messages on the control panel

**Note:** The control panel lighting is switched off during rest mode. "Sb" lights up.

### Switching on rest mode

- ▶ Press and hold **Fridge** for 15 seconds until an audible signal sounds.
- ✓ "Sb" lights up.

**Note:** After approx. 80 hours, the appliance switches to normal mode.

### Switching off rest mode

- ▶ Press and hold **Fridge** for 15 seconds until an audible signal sounds.

---

# 9 Alarm

## 9.1 Door alarm

If the appliance door is open for a while, the door alarm switches on. A warning tone sounds and "alarm" flashes.

## Switching off the door alarm

- ▶ Close the appliance door or press any touch field on the control panel.
- ✓ The warning tone is switched off.
- ✓ "alarm" goes out.

## 9.2 Temperature alarm

If the freezer compartment becomes too warm, the temperature alarm is switched on.

A warning tone sounds and the set temperature (freezer compartment) and "alarm" flash.

### CAUTION

#### Risk of harm to health!

During the thawing process, bacteria may multiply and spoil the frozen food.

- ▶ Do not refreeze food after it has been defrosted or started to defrost.
- ▶ Refreeze food only after cooking.
- ▶ These items should no longer be stored for the maximum storage period.

The temperature alarm can be switched on in the following cases:

- The appliance is switched on. Do not store any food until the appliance has reached the set temperature.
- Large quantities of fresh food are being placed inside. Switch on Super freezing before placing large quantities of food in the appliance.
- The freezer compartment door is open for too long. Check whether the frozen food has defrosted or thawed.

## Switching off the temperature alarm

- ▶ Press any touch field.
- ✓ The warning tone is switched off.
- ✓ The temperature display (freezer compartment) briefly indicates the warmest temperature reached in the freezer compartment. The temperature display (freezer compartment) then indicates the set temperature again.
- ✓ From this time on, the warmest temperature is measured again and saved.
- ✓ "alarm" lights up until the set temperature is reached again.

---

## 10 Refrigerator compartment

You can keep meat, sausage, fish, dairy products, eggs, prepared meals and pastries in the refrigerator compartment.

The temperature can be set from 2 °C to 8 °C.

The refrigerator compartment can also be used to store highly perishable foods in the short to medium term. The lower the selected temperature, the longer the food remains fresh.

### 10.1 Tips for storing food in the refrigerator compartment

- Only store food when fresh and undamaged.
- Store food covered or in air-tight packaging.
- To avoid impeding the circulation of air and to prevent food from freezing, do not place food so that it has direct contact with the back wall.

- Allow hot food and drinks to cool down first before placing in the appliance.
- Observe the best-before date or use-by date specified by the manufacturer.

## 10.2 Chill zones in the refrigerator compartment

The air recirculation cooling system allows the air to circulate evenly in the refrigerator compartment and ensures a constant temperature at all shelves.

### Coldest zone

The coldest zone is in the storage container.

**Tip:** Store highly perishable food such as fish, sausages and meat in the coldest zone.

---

## 11 Freezer compartment

You can store frozen food, freeze food and make ice cubes in the freezer compartment.

The temperature can be set from -16 °C to -24 °C.

Long-term storage of food should be at -18 °C or lower.

The freezer compartment can be used to store perishable food long-term. The low temperatures slow down or stop the spoilage.

### 11.1 Freezing capacity

The freezing capacity indicates the quantity of food that can be frozen right through to the centre within a specific period of time. Information on freezing capacity can be found on the rating plate.

→ "Appliance", Fig. **1**/**4** Page 12

## Prerequisites for freezing capacity

1. Approx. 24 hours before storing fresh food in the appliance, switch on Super freezing.  
→ "Switching on Super freezing", Page 16
2. Store the food in the top frozen food container first.

## 11.2 Fully utilising the freezer compartment volume

Learn how to store the maximum amount of frozen food in the freezer compartment.

1. Remove all fittings from the freezer compartment. → Page 21
2. Stack food directly on the floor of the freezer compartment.

## 11.3 Tips for storing food in the freezer compartment

- Store food in air-tight packaging.
- Do not bring food which is to be frozen into contact with frozen food.
- Place the food over the whole area of the frozen food containers.
- To ensure that the air can circulate freely in the appliance, push the frozen food containers in as far as they will go.

## 11.4 Tips for freezing fresh food

- Freeze fresh and undamaged food only.
- Freeze food in portions.
- Cooked food is more suitable than food that can be eaten raw.
- Vegetables: Wash, chop up and blanch before freezing.
- Fruit: Wash, pit and perhaps peel, possibly add sugar or ascorbic acid solution.

- Food that is suitable for freezing includes baked items, fish and seafood, meat, game, poultry, eggs without shells, cheese, butter and quark, ready meals and leftovers.
- Food that is unsuitable for freezing includes lettuce, radishes, eggs in shells, grapes, raw apples and pears, yoghurt, sour cream, crème fraîche and mayonnaise.

## Packing frozen food

If you select suitable packaging material and the correct type of packaging, you can determine the product quality and prevent freezer burn.

1. Place the food in the packaging.
2. Squeeze out the air.
3. Pack food airtight to prevent it from losing flavour and drying out.
4. Label the packaging with the contents and the date of freezing.

## 11.5 Shelf life of frozen food at -18 °C

Food	Storage time
Fish, sausages, prepared meals and baked goods	up to 6 months
Poultry, meat	up to 8 months
Vegetables, fruit	up to 12 months

## 11.6 Defrosting methods for frozen food

### CAUTION Risk of harm to health!

During the thawing process, bacteria may multiply and spoil the frozen food.

- ▶ Do not refreeze food after it has been defrosted or started to defrost.

## en Defrosting

- ▶ Refreeze food only after cooking.
  - ▶ These items should no longer be stored for the maximum storage period.
  - Defrost animal-based food, such as fish, meat, cheese, quark, in the refrigerator compartment.
  - Defrost bread at room temperature.
  - Prepare food for immediate consumption in the microwave, in the oven, or on the hob.
2. Take out all of the food and store it in a cool place.  
Place ice packs (if available) onto the food.
  3. Remove all fittings and accessories from the appliance.  
→ *Page 21*
  4. Remove the shelf above the fruit and vegetable container.  
→ *Page 22*
  5. Remove the fruit and vegetable container cover.

---

## 12 Defrosting

### 12.1 Defrosting in the refrigerator compartment

The refrigerator compartment in your appliance defrosts automatically.

### 12.2 Defrosting in the freezer compartment

The fully automatic NoFrost system ensures that the freezer compartment remains frost-free. Defrosting is not required.

---

## 13 Cleaning and servicing

Customer Service must clean inaccessible points. Cleaning by customer service can give rise to costs.

### 13.1 Preparing the appliance for cleaning

1. Disconnect the appliance from the power supply.  
Unplug the appliance from the mains or switch off the circuit breaker in the fuse box.
2. Take out all of the food and store it in a cool place.  
Place ice packs (if available) onto the food.
3. Remove all fittings and accessories from the appliance.  
→ *Page 21*
4. Remove the shelf above the fruit and vegetable container.  
→ *Page 22*
5. Remove the fruit and vegetable container cover.

### 13.2 Cleaning the appliance

#### **WARNING**

#### **Risk of electric shock!**

An ingress of moisture can cause an electric shock.

- ▶ Do not use steam- or high-pressure cleaners to clean the appliance.
- Liquid in the lighting or in the controls can be dangerous.
- ▶ The rinsing water must not drip into the lighting or controls.

#### **ATTENTION**

Unsuitable cleaning products may damage the surfaces of the appliance.

- ▶ Do not use hard scouring pads or cleaning sponges.
- ▶ Do not use harsh or abrasive detergents.
- ▶ Do not use cleaning products with a high alcohol content.
- ▶ Do not use stainless-steel cleaning agents on the outside of the appliance.

If you clean fittings and accessories in the dishwasher, this may cause them to become deformed or discoloured.

- ▶ Never clean fittings and accessory in the dishwasher.

1. Prepare the appliance for cleaning.  
→ *Page 20*
2. Clean the outside of the appliance, the inside of the appliance, the fittings, the accessories and the door seals with a dish cloth, luke-warm water and a little pH-neutral detergent.
3. Dry thoroughly with a soft, dry cloth.
4. Insert the fittings and install the removable appliance parts.
5. Electrically connect the appliance.  
→ *Page 10*
6. Putting the food into the appliance.

### 13.3 Removing the fittings

If you want to clean the fittings thoroughly, remove these from your appliance.

#### Removing the shelf

- ▶ Lift the shelf at the front ①, pull it out and remove it ②.

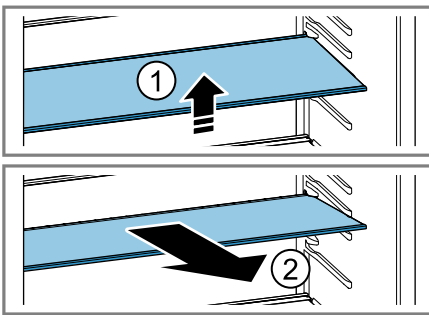

#### Removing door tray

- ▶ Lift the door tray and remove it.

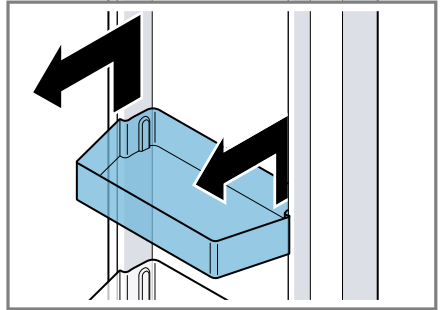

#### Removing the storage container

1. Pull out the storage container as far as it will go.
2. Lift the storage container at the front ① and remove it ②.

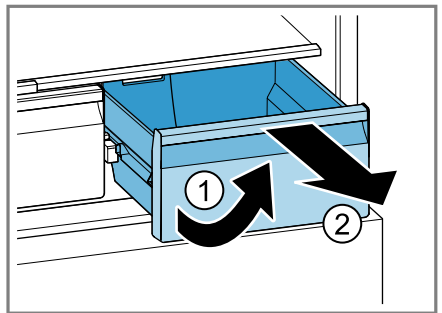

### Removing the fruit and vegetable container

1. Pull out the fruit and vegetable container as far as it will go.
2. Lift the fruit and vegetable container at the front ① and remove it ②.

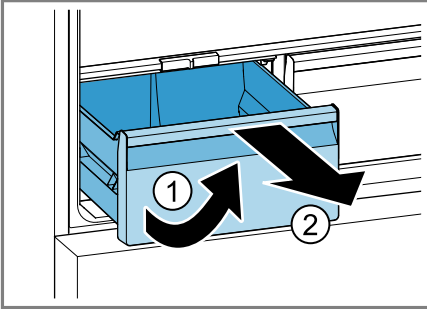

### Removing the frozen food container

1. Take out the frozen food container as far as it will go.
2. Lift the frozen food container at the front ① and remove it ②.

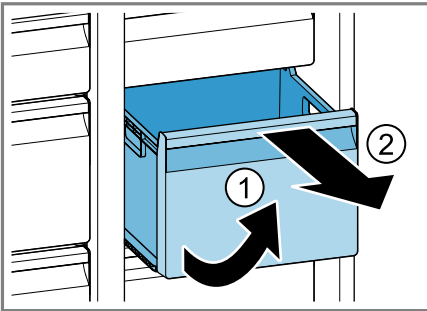

## 13.4 Removing appliance components

If you want to clean your appliance thoroughly, you can remove certain components from your appliance.

### Removing the shelf above the fruit and vegetable container

- ▶ Lift the shelf above the fruit and vegetable container at the front ① and remove it ②.

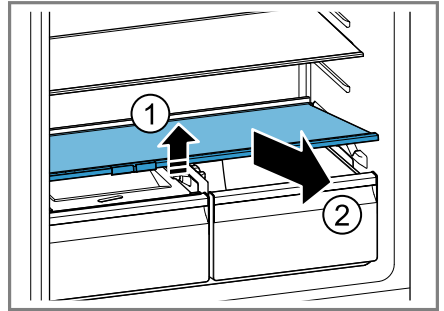

### Removing the fruit and vegetable container cover

1. Pull out the fruit and vegetable container as far as it will go.
2. Lift the fruit and vegetable container cover slightly ①, pull it forwards ② and remove it ③.

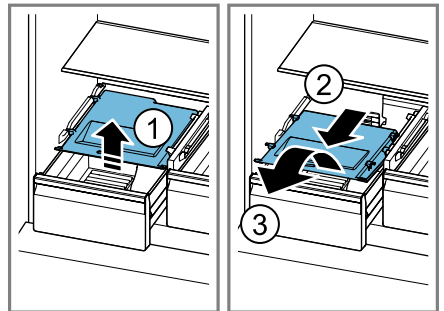

## 14 Troubleshooting



You can rectify minor faults on your appliance yourself. Read the troubleshooting information before contacting after-sales service. This will avoid unnecessary costs.

### **WARNING**

#### **Risk of electric shock!**

Improper repairs are dangerous.

- ▶ Repairs to the appliance should only be carried out by trained specialist staff.
- ▶ Only use genuine spare parts when repairing the appliance.
- ▶ If the power cord or the appliance power cable of this appliance is damaged, it must be replaced with a special power cord or special appliance power cable, which is available from the manufacturer or its Customer Service.

Fault	Cause and troubleshooting
The appliance is not cooling, the displays and lighting are lit.	<p>Showroom mode is switched on.</p> <ol style="list-style-type: none"> <li>1. Disconnect the appliance from the mains. Unplug the appliance from the mains or switch off the circuit breaker in the fuse box.</li> <li>2. Reconnect the appliance after five minutes.</li> <li>3. Wait at least 30 seconds and then press <b>mode</b> for 15 seconds.</li> </ol> <p>✓  appears briefly on the control panel.</p> <ol style="list-style-type: none"> <li>4. After a short time, check whether your appliance is cooling.</li> </ol>
The LED lighting does not work.	<p>Different causes are possible.</p> <ul style="list-style-type: none"> <li>▶ Call customer service.</li> </ul> <p>The customer service number can be found in the enclosed customer service directory.</p>
The refrigeration unit is switching on more frequently and for longer.	<p>The appliance has been opened frequently.</p> <ul style="list-style-type: none"> <li>▶ Do not open appliance door unnecessarily.</li> </ul> <hr/> <p>External ventilation openings are covered up.</p> <ul style="list-style-type: none"> <li>▶ Remove any obstructions from in front of the external ventilation openings.</li> </ul> <hr/> <p>Not a fault. Modern refrigeration machines switch on more frequently and have different power levels to cool more efficiently.</p> <div data-bbox="358 1316 476 1436" style="text-align: center;">  </div> <ul style="list-style-type: none"> <li>▶ Remove any obstructions from in front of the external ventilation openings.</li> </ul>

<b>Fault</b>	<b>Cause and troubleshooting</b>
The refrigeration unit is switching on more frequently and for longer.	<ul style="list-style-type: none"><li>▶ Install the appliance as far away as possible from heating elements, cookers and other heat sources. Avoid prolonged exposure of the appliance to direct sunlight.</li><li>▶ Only open the appliance door as briefly as necessary.</li><li>▶ Allow hot food and drinks to cool down first before storing in the appliance.</li></ul>
A layer of frost forms on the back wall of the refrigerator compartment.	<p>Not a fault. Modern refrigeration machines ensure a more even temperature in the refrigerator compartment. The back wall of the refrigerator compartment is defrosted automatically at regular intervals.</p>  <ul style="list-style-type: none"><li>▶ Only open the appliance door as briefly as necessary.</li><li>▶ Pack the food airtight or cover it.</li><li>▶ Allow hot food and drinks to cool down first before storing in the appliance.</li><li>▶ Always leave some space between the food and the interior walls.</li></ul>
"E" or "d" appears on the temperature display.	<p>The electronics have detected a fault.</p> <ol style="list-style-type: none"><li>1. Switch off the appliance. → <i>Page 15</i></li><li>2. Disconnect the appliance from the mains. Unplug the appliance from the mains or switch off the circuit breaker in the fuse box.</li><li>3. Reconnect the appliance after five minutes.</li><li>4. If the message still appears on the display, call Customer Service.</li></ol> <p>The customer service number can be found in the enclosed customer service directory.</p>
A warning signal sounds and "alarm" flashes. The door alarm is switched on.	<p>The appliance door is open.</p> <ul style="list-style-type: none"><li>▶ Close the appliance door.</li></ul>

<b>Fault</b>	<b>Cause and troubleshooting</b>
<p>A warning tone sounds and the temperature display (freezer compartment) and "alarm" flash. The temperature alarm is switched on.</p>	<p>Different causes are possible.</p> <ol style="list-style-type: none"> <li>1. Press any touch field.</li> <li>✓ The alarm is switched off.</li> <li>2. After several hours, check whether the set freezer compartment temperature has been reached again.</li> </ol> <hr/> <p>External ventilation openings are covered up.</p> <ul style="list-style-type: none"> <li>▶ Remove any obstructions from in front of the external ventilation openings.</li> </ul> <hr/> <p>Larger quantities of fresh food have been put in.</p> <ul style="list-style-type: none"> <li>▶ Switch on Super freezing before placing a larger amount of food in the appliance.</li> </ul> <p>→ <i>"Switching on Super freezing", Page 16</i></p>
<p>The temperature differs greatly from the setting.</p>	<p>Different causes are possible.</p> <ol style="list-style-type: none"> <li>1. Switch off the appliance. → <i>Page 15</i></li> <li>2. Switch the appliance back on after five minutes. → <i>Page 15</i></li> </ol> <ul style="list-style-type: none"> <li>▶ If the temperature is too warm, check the temperature again after a couple of hours.</li> <li>▶ If the temperature is too cold, check the temperature again on the following day.</li> </ul>
<p>The appliance hums, bubbles, buzzes, gargles, clicks or crackles.</p>	<p>Not a fault. A motor is running, e.g. refrigerating unit, fan. Refrigerant flows through the pipes. The motor, switches or solenoid valves are switching on or off. Automatic defrosting is running. No action required.</p>
<p>The appliance makes noises.</p> 	<p>The appliance is not level.</p> <ul style="list-style-type: none"> <li>▶ Align the appliance using a spirit level and the screw feet.</li> </ul> <hr/> <p>The appliance is not free-standing.</p> <ul style="list-style-type: none"> <li>▶ Observe the minimum clearances for the appliance.</li> </ul> <hr/> <p>Fittings wobble or stick.</p> <ul style="list-style-type: none"> <li>▶ Check the removable fittings and, if required, replace these.</li> </ul> <hr/> <p>Bottles or containers are touching.</p> <ul style="list-style-type: none"> <li>▶ Move the bottles or containers away from each other.</li> </ul> <hr/> <p>Super freezing is switched on. No action required.</p>

### 14.1 Power failure

During a power failure, the temperature in the appliance rises; this re-

duces the storage time and the quality of the frozen food.

On the website for your appliance, the technical data provides you with the storage times for frozen food in the event of a fault.

### Notes

- Open the appliance as little as possible during a power failure and do not place any other food in the appliance.
- Check the quality of the food immediately after a power failure.
  - Dispose of any frozen food that has defrosted and is hotter than 5 °C.
  - Cook or fry slightly thawed frozen food, and then either consume it or freeze it again.

## 14.2 Conducting an appliance self-test

Your appliance has an appliance self-test which displays faults that can be eliminated by your customer service.

1. Disconnect the appliance from the power supply.  
Unplug the appliance from the mains or switch off the circuit breaker in the fuse box.
2. Electrically reconnect the appliance after 5 minutes. → *Page 10*
3. Within the first two minutes after switching on, press and hold **mode** for 10 seconds until an audible signal sounds.
  - ✓ The appliance self-test starts.
  - ✓ If, at the end of the appliance self-test, 2 audible signals sound and the temperature display indicates the set temperature, the temperature sensors on your appliance are OK. The appliance switches to normal operation.
  - ✓ If, at the end of the appliance self-test, 5 audible signals sound, inform customer service.

---

## 15 Storage and disposal

### 15.1 Taking the appliance out of operation

1. Disconnect the appliance from the power supply.  
Unplug the appliance from the mains or switch off the circuit breaker in the fuse box.
2. Remove all of the food.
3. Clean the appliance. → *Page 20*
4. **ATTENTION** – Objects jammed between the door and the housing may damage the door hinge.
  - ▶ Open the door until it remains open by itself.
  - ▶ Do not insert any objects between the door and the housing.

To guarantee the ventilation inside the appliance, leave the appliance open.

### 15.2 Disposing of old appliance

Valuable raw materials can be re-used by recycling.

#### **WARNING**

#### **Risk of harm to health!**

Children can lock themselves in the appliance, thereby putting their lives at risk.

- ▶ Leave shelves and containers inside the appliance to prevent children from climbing in.
- ▶ Keep children away from the redundant appliance.

**⚠ WARNING****Risk of fire!**

If the tubes are damaged, flammable refrigerant and harmful gases may escape and ignite.

▶ Do not damage the tubes of the refrigerant circuit or the insulation.

1. Unplug the appliance from the mains.
2. Cut through the power cord.
3. Dispose of the appliance in an environmentally friendly manner. Information about current disposal methods are available from your specialist dealer or local authority.



This appliance is labelled in accordance with European Directive 2012/19/EU concerning used electrical and electronic appliances (waste electrical and electronic equipment - WEEE). The guideline determines the framework for the return and recycling of used appliances as applicable throughout the EU.

## 16 Customer Service

Function-relevant genuine spare parts according to the corresponding Eco-design Directive can be obtained from Customer Service for a period of at least 10 years from the date on which your appliance was placed on the market within the European Economic Area.

Furthermore, our Customer Service will continue to provide you with other function-relevant and storable genuine spare parts for up to

15 years from the date on which your appliance was placed on the market. For more information, please contact our Customer Service team.

**Note:** Under the terms of the manufacturer's warranty applicable to the location, the use of Customer Service is free of charge. The minimum duration of the warranty (manufacturer's warranty for private consumers) in the European Economic Area is 2 years according to the terms of warranty applicable to the location. The terms of warranty do not affect other rights or claims held by yourself under local legislation.

Detailed information about the warranty period and the warranty conditions in your country is available via the QR code on the enclosed document on service contacts and warranty conditions, from our customer service or on our website.

You can find the contact details for our customer service via the QR code on the enclosed document on service contacts and warranty conditions or on our website.

### 16.1 Product number (E-Nr.) and production number (FD)

If you contact Customer Service, you will require the product number (E-Nr.) and the production number (FD), which you can find on the appliance's rating plate.

→ "Appliance", Fig. **1** / **4** Page 12

Make a note of your appliance's details and the Customer Service telephone number to find them again quickly.

## 17 Technical data

Refrigerant, cubic capacity and further technical specifications can be found on the rating plate.

→ "Appliance", Fig. **1**/**4** Page 12

This product contains a light source from energy efficiency class E. The light source is available as a spare part and should only be replaced by trained specialist staff.

You can find more information about your model online at <https://eprel.ec.europa.eu/><sup>1</sup>. This web address is linked to the official EU EPREL product database. Please then follow the instructions on searching for the model. The model identifier is made up of the characters before the slash in the product number (E-Nr.) on the rating plate. Alternatively, you can also find the model identifier in the first line of the EU energy label.

---

<sup>1</sup> Only applies to countries in the European Economic Area









## Many thanks for choosing a Bosch home appliance!

Register your new appliance now on MyBosch and benefit directly from:

- **Expert advice and tips to make the most of your appliance**
- **Options for warranty extension**
- **Discounts on spare parts and accessories**
- **Digital information for use and all appliance data to hand**
- **Easy access to Bosch Home Appliance Service**

Simple to register, free of charge – including on mobile devices:

**[www.bosch-home.com/welcome](http://www.bosch-home.com/welcome)**

**BOSCH**  
HOME APPLIANCES  
**SERVICE**

## Need some help? You can find it here.

Expert advice on your Bosch home appliances, help with problems or repairs by professionals from Bosch.

Discover all the different ways Bosch can assist you:

**[www.bosch-home.com/service](http://www.bosch-home.com/service)**

The contact details of all countries are listed in the attached service directory.

**BSH Hausgeräte GmbH**  
Carl-Wery-Straße 34  
81739 München, GERMANY  
[www.bosch-home.com](http://www.bosch-home.com)

A Bosch Company

Valid within Great Britain:  
Imported to Great Britain by  
BSH Home Appliances Ltd.  
Grand Union House  
Old Wolverton Road  
Wolverton, Milton Keynes  
MK12 5PT  
United Kingdom



**9001690354** (060213)

en