



Free standing cooker

HXC39AG.1Q

[en] User manual and installation instructions

Bosch BetterFood app

Discover your new appliance with a thousand flexible recipes!

- Vegan, low-carb or gluten-free? You can adapt all the recipes to your preferences.
- Discover recipes for the ingredients you already have at home.
- Healthy cooking made easy thanks to the Nutri-Check health compass.
- Get the optimum settings for your connected appliances in recipes.

This app is only available in certain European countries and languages.



You can find additional information and explanations online.
Scan the QR code on the title page.



Table of contents

INFORMATION FOR USE

1	Safety	2	12	Rapid heating	19
2	Preventing material damage	6	13	Time-setting options	20
3	Environmental protection and saving energy	8	14	Childproof lock	21
4	INSTALLATION AND CONNECTION	9	15	Cleaning and servicing	21
5	Familiarising yourself with your appliance	11	16	Cleaning aid	24
6	Accessories	14	17	Rails	25
7	Before using for the first time	15	18	Appliance door	26
8	Cookware	16	19	Troubleshooting	28
9	Operating the hotplate	16	20	Transportation and disposal	30
10	Operating the electric hotplate	18	21	Customer Service	30
11	Basic operation	19	22	How it works	31
			23	INSTALLATION INSTRUCTIONS	33
			23.1	General information	33

1 Safety

Observe the following safety instructions.

1.1 Definition of the signal words

This is where you can find explanations for the safety signal words used in this manual.

WARNING

This indicates that death or serious injuries may occur as a result of non-observance of this warning.

ATTENTION

This indicates that damage to the appliance or other material damage may occur as a result of non-compliance with this warning.

Note: This alerts you to important information.

1.2 Intended use

Read the information on intended use to ensure that you use the appliance correctly and safely.

Appliance class: Class 1

The figures in these instructions are intended for information purposes.

ATTENTION: Observe the applicable regulations and only set up the appliance in well-ventilated rooms. Read through the instruc-

tions before setting up and using the appliance.

CAUTION – Risk of injury!

This appliance is for cooking purposes only.

- It shall not be used for other purposes, for example room heating.

Only allow a trained professional to connect the appliance and to convert the appliance to a different type of gas.

The appliance must be installed and the electric and gas connections must be implemented in accordance with the instruction and installation manual.

An incorrect connection or incorrect settings may lead to serious accidents and damage to the appliance.

The appliance manufacturer accepts no liability for damage of this kind.

The appliance's warranty becomes void.

Only a licensed professional may connect appliances without plugs. Damage caused by incorrect connection is not covered under the warranty.

Only use the appliance as follows:

- To prepare meals and drinks.

- Under supervision. Never leave the appliance unattended when cooking for short periods.
- in private households and in enclosed spaces in a domestic environment.
- Up to an altitude of 2000 m above sea level.

Do not use the appliance:

- On boats or in vehicles.
- as a room heater.
- with an external timer or a remote control.

Call the after-sales service if you want to convert your appliance to a different type of gas. You cannot operate the appliance with a timer or remote control.

Always place accessories in the cooking compartment the right way round.

1.3 Restriction on user group

Do not let children play with the appliance. Children must not perform cleaning or user maintenance unless they are at least 15 years old and are being supervised. Keep children under the age of 8 years away from the appliance and power cable.

1.4 Safe use

⚠ **WARNING – Risk of explosion!**

Escaping gas may cause an explosion.

WHAT TO DO IF YOU SMELL GAS OR IF THERE ARE FAULTS IN THE GAS INSTALLATION

- ▶ Immediately shut off the gas supply or close the gas cylinder valve.
- ▶ Immediately extinguish all naked flames and cigarettes.
- ▶ Do not operate any light switches or appliance switches.
- ▶ Do not pull any plugs out of any sockets.
- ▶ Do not use any telephones or mobile phones within the building.
- ▶ Open windows and ventilate the room.
- ▶ Call the after sales service or the gas supplier.

Escaping gas may cause an explosion. Small amounts of gas can collect over a longer period of time and ignite.

- ▶ Close the safety valve for the gas supply when the appliance is out of use for prolonged periods.

Escaping gas may cause an explosion.

If the liquefied gas bottle is not upright, liquefied propane/butane can enter the appliance. Intense darting flames may therefore escape from the burners. Components may become

damaged and start to leak over time so that gas escapes uncontrollably.

- ▶ Always use liquefied gas bottles in an upright position.

Escaping gas may cause an explosion.

If the gas pressure in your distributing pipes is more than 20% higher than the values specified on the appliance's rating plate, a gas leak can occur.

- ▶ For your own safety, it is imperative that you operate the appliance with a suitable gas governor.
- ▶ If you do not know what the gas pressure in your gas distributing pipes is, please ask your local gas company.
- ▶ Connection, maintenance and setting of the gas governor must be carried out by an authorised installation specialist.

⚠ **WARNING – Risk of poisoning!**

The use of a gas cooking appliance results in the production of heat, moisture and products of combustion in the room in which it is installed. Ensure that the kitchen is well ventilated especially when the appliance is in use.

- ▶ Prolonged intensive use of the appliance may require additional ventilation, for example the increasing of mechanical ventilation where present, additional ventilation to safely remove the products of combustion to outside (external) air whilst also providing room air changes with additional ventilation.
- ▶ Consult a professional before installation of the additional ventilation.

⚠ **WARNING – Risk of fire!**

The appliance will become hot.

- ▶ Do not keep combustible objects or aerosol cans in drawers directly underneath the hob.
- ▶ Never store or use combustible materials (e.g. spray cans or cleaning agents) under the appliance or in its immediate vicinity.

The cooking surface becomes very hot.

- ▶ Never place flammable objects on the cooking surface or in its immediate vicinity.
 - ▶ Never place objects on the cooking surface.
- Leaving fat or oil cooking on an unattended hob can be dangerous and may lead to fires.
- ▶ Never leave hot oil or fat unattended.
 - ▶ Never attempt to extinguish a fire using water; instead, switch off the appliance and then cover with a lid or a fire blanket.

Hob covers can cause accidents, for example due to overheating, catching fire or materials shattering.

- ▶ Do not use hob covers.

The appliance becomes very hot, fabrics and other objects may ignite.

- ▶ Keep fabrics (e.g. garments or curtains) away from the flames.
- ▶ Never reach over the flames.
- ▶ Do not place combustible objects (e.g. tea towels or newspapers) on, next to or behind the appliance.

Escaping gas may ignite.

- ▶ If the burner does not ignite after 15 seconds, turn the control knob to the "Off" position and open the door or window in the room. Do not attempt to re-ignite the burner for at least one minute.
- ▶ In the event of the burner flames being accidentally extinguished, turn off the burner control. Do not attempt to re-ignite the burner for at least one minute.

Opening the appliance door creates a draught. Greaseproof paper may come into contact with the heating element and catch fire.

- ▶ Never place greaseproof paper loosely over accessories when preheating the appliance and while cooking.
- ▶ Always cut greaseproof paper to size and use a plate or baking tin to hold it down.

Combustible objects that are left in the cooking compartment may catch fire.

- ▶ Never store combustible objects in the cooking compartment.

The rear of the appliance becomes very hot.

- ▶ This may cause damage to the power cables.
- ▶ Electricity and gas lines must not come into contact with the rear of the appliance.

Food may catch fire.

- ▶ The cooking process must be monitored. A short process must be monitored continuously.

When gas burners are in operation without any cookware placed on them, they can build up a lot of heat. The extractor hood above it may become damaged or catch fire.

- ▶ Only operate the gas burners with cookware on them.

Loose food remnants, fat and meat juices may catch fire.

- ▶ Before using the appliance, remove the worst of the food residues and remnants

from the cooking compartment, heating elements and accessories.

Overheating of the appliance may cause a fire.

- ▶ Never install the appliance behind a decorative door or unit door.

It is dangerous to use an extended power cord and non-approved adapters.

- ▶ Do not use extension cables or multiple socket strips.
- ▶ Only use adapters and power cords approved by the manufacturer.
- ▶ If the power cord is too short and a longer one is not available, please contact an electrician to have the domestic installation adapted.

⚠ **WARNING – Risk of burns!**

The accessible parts can become hot during operation.

- ▶ Small children should be kept away from the appliance.

Hob protective grilles may cause accidents.

- ▶ Never use hob guards.

Accessories and cookware get very hot.

- ▶ Always use oven gloves to remove accessories or cookware from the cooking compartment.

Empty cookware becomes extremely hot when set on gas burners that are operating.

- ▶ Never heat up empty cookware.

The appliance becomes hot during operation.

- ▶ Allow the appliance to cool down before cleaning.

When the cooking compartment is hot, any alcoholic vapours inside may catch fire.

- ▶ Only use small quantities of drinks with a high alcohol content in food.

- ▶ Open the appliance door carefully.

The appliance and its parts that can be touched become hot during use.

- ▶ Caution should be exercised here in order to avoid touching heating elements.
- ▶ Young children under 8 years of age must be kept away from the appliance.

Accessible points may be hot when using the grill.

- ▶ Keep small children away from the appliance.

When the cooking compartment is hot, any alcoholic vapours inside may catch fire. The appliance door may spring open. Hot steam and jets of flame may escape.

- ▶ Only use small quantities of drinks with a high alcohol content in food.

- ▶ Do not heat spirits ($\geq 15\%$ vol.) when undiluted (e.g. for marinating or pouring over food).
- ▶ Open the appliance door carefully.

⚠ WARNING – Risk of electric shock!

Improper repairs are dangerous.

- ▶ Repairs to the appliance should only be carried out by trained specialist staff.
- ▶ Only use genuine spare parts when repairing the appliance.
- ▶ If the power cord of this appliance is damaged, it must be replaced by the manufacturer, the manufacturer's Customer Service or a similarly qualified person in order to prevent any risk.

If the appliance or the power cord is damaged, this is dangerous.

- ▶ Never operate a damaged appliance.
- ▶ Never operate an appliance with a cracked or fractured surface.
- ▶ Never pull on the power cord to unplug the appliance. Always unplug the appliance at the mains.
- ▶ If the appliance or the power cord is damaged, immediately unplug the power cord or switch off the fuse in the fuse box and turn off the gas supply.

▶ Call customer service. → *Page 30*

An ingress of moisture can cause an electric shock.

- ▶ Do not use steam- or high-pressure cleaners to clean the appliance.

The insulation on cables of electrical appliances may melt if it touches hot parts of the appliance.

- ▶ Never bring electrical appliance cables into contact with hot parts of the appliance.

If the insulation of the power cord is damaged, this is dangerous.

- ▶ Never let the power cord come into contact with hot appliance parts or heat sources.
- ▶ Never let the power cord come into contact with sharp points or edges.
- ▶ Never kink, crush or modify the power cord.

⚠ WARNING – Risk of injury!

Faults or damage to the appliance and repairs that have not been carried out correctly are dangerous.

- ▶ Never switch on the appliance if there is a fault with it.
- ▶ If the appliance is faulty, unplug the mains plug or switch off the fuse in the fuse box.

Shut off the gas supply and call the after sales service.

- ▶ Always have repairs carried out to the appliance and damaged gas lines replaced by trained, specialist personnel.

Cookware that is not the right size, or that is damaged or incorrectly positioned may cause serious injuries.

- ▶ See the notes on cookware.

When switching on the burner, sparks are generated in the ignition plugs.

- ▶ Never touch the ignition plugs while the burner is being lit.

The hinges on the appliance door move when the door is opened and closed, which could trap your fingers.

- ▶ Keep your hands away from the hinges. Scratched glass in the appliance door may develop into a crack.

- ▶ Do not use any harsh or abrasive cleaners or sharp metal scrapers to clean the glass on the oven door, as they may scratch the surface.

If you leave the appliance door open, people may bump into it, resulting in injury.

- ▶ Always keep the appliance door closed during and after operation.

Components inside the appliance door may have sharp edges.

- ▶ Wear protective gloves.

The appliance and its parts that can be touched may have sharp edges.

- ▶ Take care when handling and cleaning them.
- ▶ If possible, wear protective gloves.

⚠ WARNING – Risk of scalding!

The accessible parts of the appliance become hot during operation.

- ▶ Never touch these hot parts.
- ▶ Keep children at a safe distance.

Hot steam may escape when you open the appliance door. Steam may not be visible, depending on the temperature.

- ▶ Open the appliance door carefully.
- ▶ Keep children at a safe distance.

If there is water in the cooking compartment when it is hot, this may create hot steam.

- ▶ Never pour water into the cooking compartment when the cooking compartment is hot.

⚠ WARNING – Risk of harm to health!

When heating up the hotplate for the first time, vapours are released which may lead to irritation of the mucous membranes.

- ▶ The kitchen should therefore be well ventilated.
- ▶ Stay in the kitchen for a short time.
- ▶ Keep children, pets and particularly vulnerable people away from the room.

⚠ WARNING – Risk of suffocation!

Children may put packaging material over their heads or wrap themselves up in it and suffocate.

- ▶ Keep packaging material away from children.
- ▶ Do not let children play with packaging material.

Children may breathe in or swallow small parts, causing them to suffocate.

- ▶ Keep small parts away from children.
- ▶ Do not let children play with small parts.

⚠ WARNING – Risk of tipping!

If the appliance is placed on a base and is not secured, it may slide off the base.

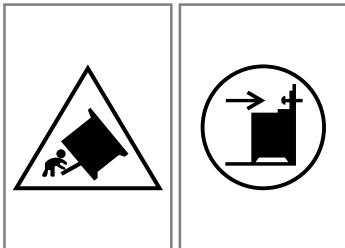

- ▶ Connect the appliance securely to the base.

- ▶ Warning: To prevent the appliance from tipping over, attach a compensation device.
- ▶ Observe the instructions for the installation.

1.5 Plinth drawer

⚠ WARNING – Risk of fire!

The surfaces of the plinth drawer may become very hot.

- ▶ Only store oven accessories in the drawer.
- ▶ Do not keep any flammable or combustible objects in the plinth drawer.

1.6 Halogen bulb

⚠ WARNING – Risk of burns!

The bulbs in the cooking compartment get very hot. There is still a risk of burning for some time after they have been switched off.

- ▶ Do not touch the glass cover.
- ▶ Avoid contact with your skin when cleaning.

⚠ WARNING – Risk of electric shock!

When changing the bulb, the bulb socket contacts are live.

- ▶ Before replacing the bulb, ensure that the appliance is switched off in order to prevent a potential electric shock.

2 Preventing material damage

2.1 Oven area

Follow the corresponding instructions when using the oven.

ATTENTION

Objects on the cooking compartment floor at over 50 °C will cause heat to build up. The baking and roasting times will no longer be correct and the enamel will be damaged.

- ▶ Do not place any accessories, greaseproof paper or foil of any kind on the cooking compartment floor.
- ▶ Only place cookware on the cooking compartment floor if a temperature under 50 °C has been set.

If aluminium foil comes into contact with the door pane, it could cause permanent discolouration.

- ▶ Do not allow aluminium foil in the cooking compartment to come into contact with the door pane.

When the cooking compartment is hot, any water inside it will create steam. The change in temperature may cause damage.

- ▶ Never pour water into the cooking compartment when it is still hot.
- ▶ Never place cookware containing water on the cooking compartment floor.

The prolonged presence of moisture in the cooking compartment leads to corrosion.

- ▶ Allow the cooking compartment to dry after use.
- ▶ Do not keep moist food in the cooking compartment for a long time with the door closed.
- ▶ Do not store food in the cooking compartment.
- ▶ Take care not to trap anything in the appliance door. Leaving the appliance to cool down with the door open will damage the front of neighbouring kitchen units over time.
- ▶ Always allow the cooking compartment to cool down with the door closed after cooking at high temperatures.

- ▶ Take care not to trap anything in the appliance door.
- ▶ Only leave the cooking compartment to dry with the door open if a lot of moisture was produced during operation.

Fruit juice dripping from the baking tray leaves stains that cannot be removed.

- ▶ When baking very juicy fruit flans, do not pack too much on the baking tray.
- ▶ If possible, use the deeper universal pan.

Using oven cleaner in a hot cooking compartment damages the enamel.

- ▶ Never use oven cleaner in the cooking compartment when it is still warm.
- ▶ Remove all food remnants from the cooking compartment and the appliance door before you next heat up the appliance.

If the seal is very dirty, the appliance door will no longer close properly during operation. This may damage the front of adjacent kitchen units.

- ▶ Keep the seal clean at all times.
- ▶ Never operate the appliance if the seal is damaged or missing.

Sitting or placing objects on the appliance door may damage it.

- ▶ Do not place, hang or support objects on the appliance door.
- ▶ Do not place cookware or accessories on the appliance door.

If you carry or move the appliance by the handle on the cover or move, the handle may break off and cause damage to the hinges. The handle of the cover is not designed for the weight of the appliance.

- ▶ Do not carry or move the appliance by the handle on the cover.

When grilling, due to high temperatures, the baking tray or universal pan may become deformed and damage the enamel coating when they are removed.

- ▶ When grilling, do not insert the baking tray or universal pan higher than level 3.
- ▶ Above shelf position 3, only grill directly on the wire insert.

2.2 Hob with gas

Follow the corresponding instructions when using the appliance.

ATTENTION

A build-up of heat may damage the appliance.

- ▶ Never cover the stainless steel hob, for example with aluminium foil or oven protectors.
- ▶ Only use the accessories specified.

Heat can cause damage to adjacent appliances or kitchen units.

If the appliance is in operation for an extended period, heat and moisture will be generated.

- ▶ Open a window or switch on an extractor hood leading to the outside.

A build-up of heat may damage the appliance.

- ▶ Do not heat roasters, frying pans or grill stones using more than one burner at a time.

If a control knob is in the wrong position, this could lead to malfunctions.

- ▶ Always turn the control knob to the "Off" position when the appliance is not being used.

Aluminium foil and plastic containers will melt and adhere to hot cooking zone.

- ▶ Observe the manufacturer's instructions for special containers.
- ▶ No not use oven liners.

The burner may not ignite or the burner flame is not even.

- ▶ Ensure that the hotplate burners are clean and dry.
- ▶ The burner cup and burner cover must be in exactly the right position.

Food may spill.

- ▶ Remove spills immediately.
- ▶ Use deep pots for dishes with a lot of liquid.
- ▶ This prevents overflowing.

Penetrating liquid may cause damage to the appliance.

- ▶ The area around the appliance must be clean and dry.
- ▶ Always keep the appliance and the area around it clean and dry after cleaning.
- ▶ Ensure that there are no cleaning materials, cleaning products or water marks on any of the appliance's surfaces.

The handles or grips on pots or pans may be damaged.

- ▶ Place the pot or pan precisely in the centre of the steel grid of the burner.
- ▶ This will optimise transfer of the heat from the burner flame to the pot or pan base.
- ▶ The handle or grip does is not damaged, and greater energy savings are guaranteed.

The base of the pot or pan may be damaged.

- ▶ Cookware that is used on the hotplate must be securely in place.
- ▶ Only use pots and pans with an even base.
- ▶ Do not heat up empty pots or pans.

Damage may occur if hard or pointed objects fall on the hob.

- ▶ Do not let hard or pointed objects fall onto the hob.

Do not hold and move the appliance at the gas pipe (collector). Damage to the gas pipe may lead to gas leak. The gas pipe is not designed for the weight of the appliance.

- ▶ Do not hold and move the appliance at the gas pipe.
- If you are cleaning food remnants or residue liquids that are penetrating below the hotplates into the the burner seat using lyes or similar chemicals, this may lead to damage to the gas components.

- ▶ If you remove the food remnants or residue liquids from the burner seat, do not use lye or similar effective chemicals.

Salt water or hot pot bases may cause damage to the electric hotplate.

- ▶ Keep the electric hotplate dry.

A build-up of heat on the electric hotplate may cause damage.

- ▶ Ensure that the electric hotplate is never switched on when the hob cover is on, e.g. by children playing.

The heat of the electric hotplate can not be discharged sufficiently and the electric hotplate may overheat.

- ▶ Never operate the electric hotplate without a pot.
- ▶ Do not use pots with an uneven base.

2.3 Electric hob

Follow the corresponding instructions when using the appliance.

ATTENTION

Food may spill.

- ▶ Remove spills immediately.
- ▶ Use deep pots for dishes with a lot of liquid.
- ▶ This prevents overflowing.

The base of the pot or pan may be damaged.

- ▶ Cookware that is used on the hotplate must be securely in place.
- ▶ Only use pots and pans with an even base.
- ▶ Do not heat up empty pots or pans.

A build-up of heat on the electric hotplate may cause damage.

- ▶ Ensure that the electric hotplate is never switched on when the hob cover is on, e.g. by children playing.

Salt water or hot pot bases may cause damage to the electric hotplate.

- ▶ Keep the electric hotplate dry.

The heat of the electric hotplate can not be discharged sufficiently and the electric hotplate may overheat.

- ▶ Never operate the electric hotplate without a pot.
- ▶ Do not use pots with an uneven base.

2.4 Drawer area

Follow the corresponding instructions when using the drawer.

ATTENTION

Do not place hot objects in the plinth drawer. The plinth drawer may be damaged.

- ▶ Do not place hot objects in the plinth drawer.
- Do not place oven accessories that exceed the height of the drawer into the plinth drawer. Otherwise, this may damage the appliance.
- ▶ Do not place oven accessories that exceed the height of the drawer into the plinth drawer.

3 Environmental protection and saving energy

3.1 Disposing of packaging

The packaging materials are environmentally compatible and can be recycled.

- ▶ Sort the individual components by type and dispose of them separately.

3.2 Saving energy

If you follow these instructions, your appliance will use less energy.

Only preheat the appliance if the recipe or the recommended settings tell you to do so.

- ✓ Not preheating the appliance can reduce the energy used by up to 20%.

Use dark-coloured, black-coated or enamelled baking tins.

- ✓ These types of baking tin absorb the heat particularly well.

Open the appliance door as little as possible during operation.

- ✓ This maintains the temperature in the cooking compartment and eliminates the need for the appliance to reheat.

When baking multiple dishes, do so in succession or in parallel.

- ✓ The cooking compartment is heated after baking the first dish. This reduces the baking time for the subsequent cakes.

For longer cooking times, you can switch the appliance off 10 minutes before the cooking time ends.

- ✓ There is sufficient residual heat to finish cooking the dish.

Remove any accessories that are not being used from the cooking compartment.

- ✓ Accessories that are not being used do not need to be heated.

Allow frozen food to defrost before cooking.

- ✓ This saves the energy that would otherwise be required to defrost it.

Saving energy

If you follow these instructions, your appliance will use less energy.

Choose a burner roughly the same size as your pan. Centre the cookware on the hob.

Tip: Cookware manufacturers often give the upper diameter of the saucepan. It is often larger than the base diameter.

- ✓ Unsuitable cookware or incompletely covered cooking zones consume a lot of energy.

Cover saucepans with suitable lids.

- ✓ Cooking without a lid consumes considerably more energy.

Lift lids as infrequently as possible.

- ✓ When you lift the lid, a lot of energy escapes.

Using a glass lid

- ✓ You can see into the pan through a glass lid without having to lift it.

Use pots and pans with flat bases.

- ✓ Uneven bases increase energy consumption.

Use cookware that is suitable for the quantity of food.

- ✓ Large items of cookware containing little food need more energy to heat up.

Cook with only a little water.

- ✓ The more water there is in the cookware, the more energy that is required to heat it up.

Turn down to a lower power level early on.

- ✓ If you use an ongoing power level that is too high, you will waste energy.

Use the residual heat of electric hotplates. With lengthy cooking times switch off the hotplate 5-10 minutes before the end of cooking.

- ✓ Unused residual heat increases energy consumption.

4 Installation and connection

You can find out where and how best to install your appliance here. You will also learn how to connect your appliance to the power supply.

4.1 Gas connection

Only an authorised expert or a licensed customer service technician may install the appliance in accordance with the instructions specified under "Gas connection and conversion to a different gas type".

- The settings for configuring your appliance can be found on the rating plate on the rear of the appliance. The gas type set at the factory is marked with an asterisk (*).
- Find out about the local supply conditions regarding the gas type and gas pressure before installing the appliance, and ensure that the gas setting for the appliance complies with this information.
- Connect and install this appliance in accordance with the applicable to the installation instructions.
- Do not connect this appliance to a waste gas main on the combustion products. Do not connect this appliance to an exhaust gas outlet. Comply with all ventilation regulations.
- Establish the gas supply using a permanent, non-elastic connection, such as a gas pipe or a flexible safety gas hose.
- If a flexible safety gas hose is used, ensure that the hose is not jammed or squeezed. Keep the hose away from hot surfaces.
- On some appliances, you can connect the gas pipe to the gas pipe or flexible safety gas hose on the right-hand or the left-hand side of the appliance. If necessary, you can change the connection side. The connection must have a free-standing and easily accessible locking device.

Target appliance operating pressure

- You can find the target operating pressure for your appliance on the rating plate on the rear of the appliance.
- All the data on your appliance's rating plate relates to these pressure values.
- The manufacturer is not responsible for results, performance or any risk caused by operating the appliance at different values.

WARNING – Risk of explosion!

Escaping gas may cause an explosion.

If the gas pressure in your distributing pipes is more than 20% higher than the values specified on the appliance's rating plate, a gas leak can occur.

- ▶ For your own safety, it is imperative that you operate the appliance with a suitable gas governor.
- ▶ If you do not know what the gas pressure in your gas distributing pipes is, please ask your local gas company.
- ▶ Connection, maintenance and setting of the gas governor must be carried out by an authorised installation specialist.

A gas leak could occur.

If you move the appliance after the gas supply has been established, a gas leak could occur.

- ▶ Do not move the appliance once the gas supply is connected.
- ▶ If you move the appliance, check that the connections are not leaking.

4.2 Electrical connection

The appliance must be connected by an authorised specialist. You must comply with the requirements of your electricity supplier.

- Your appliance is designed to operate at 220–240 V. A 16 A fuse is required for connection.
- If the electricity supply drops below 180 V, the electrical ignition system does not work.
- If the power cable of this appliance is damaged, this must be replaced by the manufacturer, the manufacturer's customer service or a similarly qualified person in order to prevent any risk.
- Any damage arising from the appliance being connected incorrectly will invalidate the warranty.

Information on electrical connection by our customer service:

- Connect the appliance in accordance with the specifications on the rating plate.
- The appliance must only be connected to an electrical connection that corresponds to the applicable regulations. The socket must be easily accessible so that you can disconnect the appliance from the electricity supply if necessary.
- Ensure that a multi-pin disconnecting system is available.
- For safety reasons, this appliance must only be connected to an earthed connection. If the safety earth terminal does not comply with regulations, protection against electrical risks is not guaranteed.
- To connect the appliance, use H 05 VV-F cables or other equivalent cables.

Information on the electrical connection by the installer:

- If the plug is not accessible following installation, an all-pole isolating unit with a contact clearance of at least 3 mm must be available on the installation side. This is not necessary if the appliance is connected via a plug that is accessible to the user.
- Electrical safety: The cooker corresponds to safety class I and may only be used in conjunction with a safety earth terminal.
- To connect the appliance, use H 05 VV-F cables or other equivalent cables.

Important information about the electrical connection

Note the following information and ensure that:

WARNING – Risk of electric shock!

There is a risk of electric shock if you touch live components.

- ▶ Hold the mains plug with dry hands only.

- ▶ Never pull out the mains plug from the socket while the appliance is in operation.
- ▶ Pull out the power cable directly at the plug and never by pulling the power cable as this may become damaged.
- Fit the mains plug and socket together.
- The mains plug can be accessed at all times.
- The cross section of the cable is sufficient.
- The mains cable is not kinked, crushed, modified or severed.
- If required, the mains cable must only be replaced by a qualified electrician. A replacement mains cable is available from the after-sales service.
- Do not use any multiple plugs or multi-connectors and extension cords.
- The earthing system is correctly installed.
- If using a residual current device, only use one that bears the mark . The presence of this mark is the only way to be sure that it fulfils all the applicable regulations.
- The mains cable does not come into contact with heat sources.

4.3 Setting up the appliance

Place the appliance on a smooth surface. Never set up the appliance behind a decorative door or the door of a kitchen unit. There is a risk of overheating.

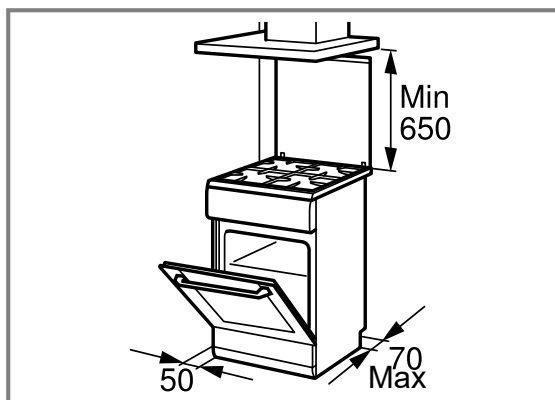

- Install the appliance in accordance with the specified dimensions.
- The distance between the top edge of the cooker and the bottom edge of the extractor hood must meet the requirements of the extractor hood manufacturer.
- Ensure that the appliance is not moved again after it is set up.
- In particular, the distance from the high-output burner or wok burner to the fronts of adjacent units or from the wall must be at least 50 mm.

Setting the base height of the appliance

Set the base height in accordance with the functions of your appliance.

Adjusting the height of the appliance with fixed drawers

If your appliance has fixed drawers, set the base height of your appliance as follows.

Note

The appliance has height-adjustable feet. This allows the appliance to be raised approx. 15 mm from the ground.

- The feet are located at the front and rear on the underside of the appliance.
- Raise or lower the feet by turning the feet with an Allen key until the appliance is in a horizontal position.

Setting the base height of the appliance with a removable drawer

If your appliance does not have height-adjustable feet and the drawer is removable, set the base height of your appliance as follows.

1. Pull out the plinth drawer and lift it up and out. There are adjustable feet at the front and rear on the inside of the plinth.
2. Use an Allen key to raise or lower the adjustable feet until the cooker is level.

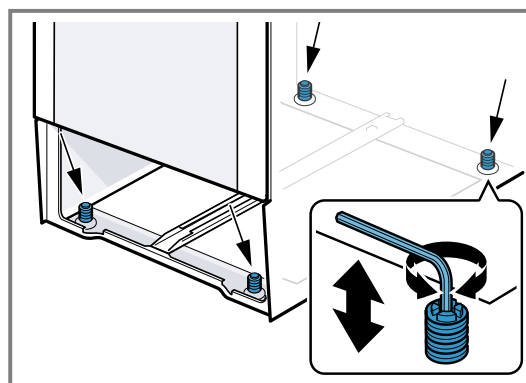

3. Push in the plinth drawer.

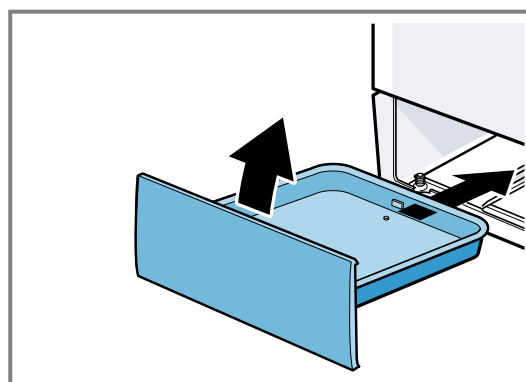

Adjacent units

Any adjacent units must not be made of flammable materials. The fronts of any adjacent units must be heat-resistant up to at least 90 °C.

Wall fixing

To prevent the appliance from tipping over, you must fix it to the wall using the enclosed brackets. To secure the appliance to the wall, follow the installation instructions.

5 Familiarising yourself with your appliance

5.1 Your appliance

You can find an overview of the parts of your appliance here.

Note: On certain models, specific details such as colour and shape may differ from those pictured.

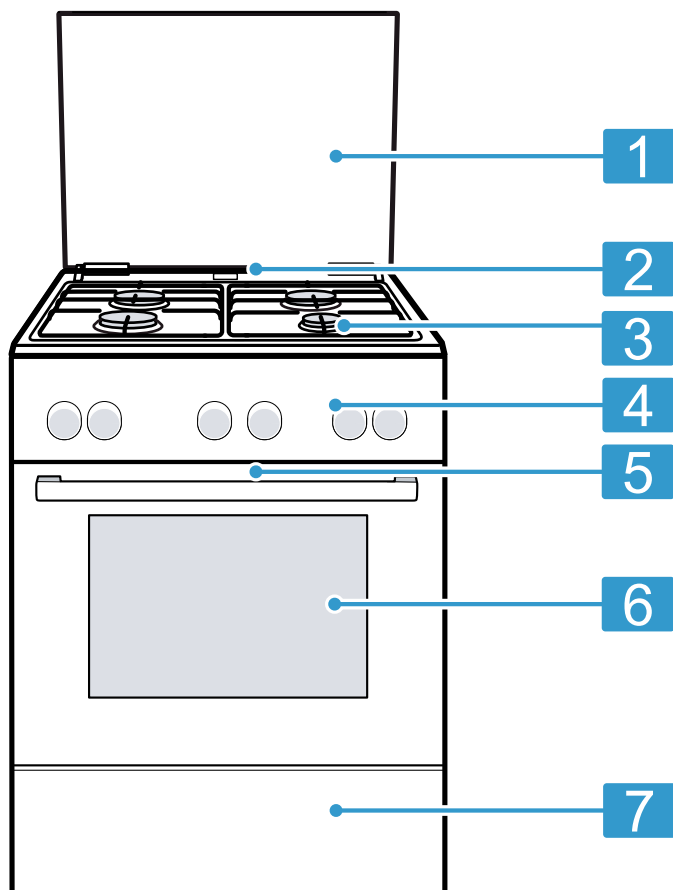

Explanation
1 Top cover ¹
2 Steam outlet ¹
3 Hob
4 Control panels
5 Cooling fan ¹
6 Appliance door
7 Plinth drawer ¹

¹ Depending on the appliance specifications

5.2 Hob

You can view an overview of the hob here.

Note: On certain models, specific details such as colour and shape may differ from those pictured.

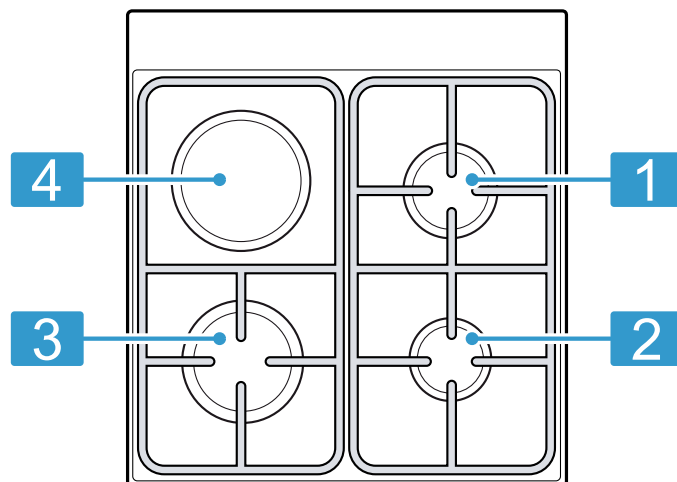

	Power kW	Burner/hotplate
1	1,75 kW	Standard-output burner
2	1 kW	Economy burner
3	3 kW	High-output burner
4	1 kW	Electric hotplate

5.3 Control panels

You can use the control panel to configure all functions of your appliance and to obtain information about the operating status.

Controls

You can use the controls to configure all functions of your appliance and to obtain information about the operating status.



Control	Explanation
Buttons and display	The buttons are touch-sensitive surfaces. To select a function, simply press lightly on the relevant field. The display shows symbols for active functions and the time-setting options. → "Buttons and display", Page 12
Function selector	Use the function selector to set the types of heating and other functions.

Control	Explanation
	<p>You can turn the function selector clockwise or anti-clockwise from the zero setting ◦.</p> <p>Depending on the appliance, the function selector can be pushed in. Press on the function selector to click it into or out of the zero setting ◦.</p> <p>→ "Types of heating and functions", Page 12</p>
Temperature selector	<p>Use the temperature selector to set the temperature for the type of heating and select settings for other functions.</p> <p>You can only turn the temperature selector clockwise from the zero setting ● until it offers resistance. You cannot turn it any further than this.</p>

Control	Explanation
	<p>Depending on the appliance, the temperature selector can be pushed in. Press on the temperature selector to click it into or out of the zero setting ●.</p> <p>→ "Temperature and setting levels", Page 13</p>
Hotplate control	<p>You can use the four hotplate switches to control the output provided by each individual hotplate. The symbol above each of the switches shows you which hotplate is set using that switch.</p> <p>→ "Gas hob selector", Page 13</p> <p>→ "Electric hob selector", Page 13</p>







Buttons and display

You can use the buttons to set various functions for your appliance. The display shows the settings. If a function is active, the corresponding symbol lights up on the display. ⌚ only lights up when you change the time.

Symbol	Function	Use
	Childproof lock	Activate or deactivate the childproof lock.
	Time-setting options	Select the time ⌚, timer ⏰, cooking time → and the end time → . To select the individual time-setting options, press ⌚ several times.
–	Minus	Decrease the setting values.
+	Plus	Increase the setting values.

Types of heating and functions

To ensure that you always use the right type of heating to cook your food, we explain the differences and applications below.

Symbol	Type of heating	What it's used for and how it works
	3D hot air	Bake or roast on one or more levels. The fan distributes the heat from the ring-shaped heating element in the back wall evenly around the cooking compartment.
	Hot air gentle	Cook selected dishes gently on one level without preheating. The fan distributes the heat from the ring-shaped heating element in the back wall evenly around the cooking compartment. The food is cooked in phases using residual heat. Select a temperature between 120 °C and 230 °C. This type of heating is used to determine the energy consumption in air recirculation mode and the energy efficiency class.
	Pizza setting	Cook pizza or food that requires a lot of heat from below. The bottom heating element and the ring-shaped heating element in the back wall heat the cooking compartment.
	Bottom heating	Final baking or cooking food in a bain marie. The heat is emitted from below.
	Full-surface grill	Grill flat items such as steak, sausages, or toast. Gratinated food. The entire area below the grill element becomes hot.
	Hot air grilling	Roast poultry, whole fish or large pieces of meat. The grill element and the fan switch on and off alternately. The fan circulates the hot air around the food.

Symbol	Type of heating	What it's used for and how it works
	Top/bottom heating	Traditionally bake or roast on one level. This type of heating is especially suitable for cakes with moist toppings. The heat is emitted evenly from above and below. This type of heating is used to determine the energy consumption in the conventional mode.
	Defrosting	Gently defrost frozen food.

Additional functions

Here, you can find an overview of other functions of your appliance.

Symbol	Function	Use
	Rapid heating	Rapidly preheat the cooking compartment without accessories. → "Rapid heating", Page 19

Temperature and setting levels

There are different settings for the types of heating and functions.

Note: For temperature settings above 250 °C, the appliance reduces the temperature to approx. 240 °C after approx. 10 minutes.

Symbol	Function	Use
•	Zero setting	The appliance does not heat up.
50–275	Temperature range	Set the temperature in the cooking compartment in °C.
1, 2, 3 or I, II, III	Grill settings	Depending on the appliance type, set the grill settings for the grill, for the large area and grill, or for the small area. 1 = low 2 = medium 3 = high

Heat-up indicator

The appliance indicates when it is heating up. When the appliance is heating, lights up on the display. This symbol goes out when heating is paused.

When you preheat the appliance, the optimal time to place your food in the cooking compartment is when the symbol first goes out.

Note: Due to thermal inertia, the temperature that is displayed may differ slightly from the actual temperature inside the cooking compartment.

Gas hob selector

The gas hotplate selector is used to set the heat setting for the hotplates.

Position	Function	Explanation
	Zero setting	The hotplate is switched off.
	Ignition position	All the igniters ignite at the same time.
	Settings range	Large flame = highest setting
		Small flame = lowest setting

There is a limit stop at the end of the settings range. Do not turn the gas hotplate selector beyond the end stop.

Electric hob selector

You can use the electric hob selector to adjust the hotplate's heat setting.

Position	Function	Explanation
0	Zero setting	The hotplate is switched off.
1–9	Power levels	1 = lowest output 9 = highest output

When you switch on the electric hotplate, the indicator lamp lights up.

Note: Depending on the appliance type, the electric hotplate does not work on some appliances when the function selector is switched on.

If you switch on the function selector on the electric hot-plate while the appliance is running, its power supply is interrupted.

5.4 Cooking compartment

The functions in the cooking compartment make your appliance easier to use.

Rails

The shelf supports in the cooking compartment enable you to place accessories at different heights. The cooking compartment has five shelf positions. The shelf positions are numbered from bottom to top. You can remove the rails, e.g. for cleaning.
→ "Rails", Page 25

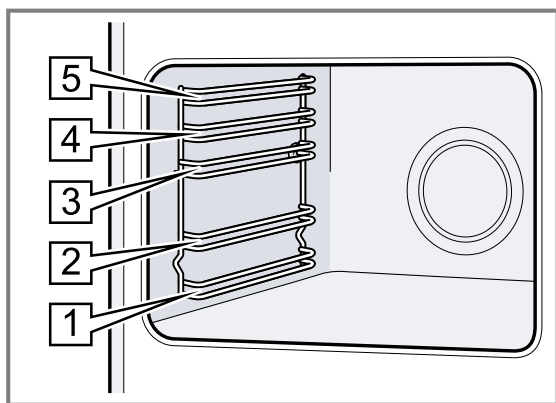

Self-cleaning surfaces

The back panel in the cooking compartment is self-cleaning. The self-cleaning surfaces are coated with a porous, matte ceramic layer and have a coarse surface. When the appliance is in operation, the self-cleaning

surfaces absorb splashes from roasting or grilling and break them down.

If the self-cleaning surfaces no longer clean themselves adequately during operation, heat up the cooking compartment specifically to the right temperature.

→ "Cleaning self-cleaning surfaces in the cooking compartment", Page 23

Lighting

The oven light lights up the cooking compartment. With most types of heating and functions, the lighting lights up during operation. If you use the function selector to end the operation, the lighting switches off.

Cooling fan

The cooling fan switches on and off depending on the appliance's temperature. The hot air escapes above the door.

ATTENTION

Do not cover the ventilation slot above the appliance door.

The appliance overheats.

- ▶ Ensure that the ventilation slots are unobstructed.

To ensure that the appliance cools down more quickly after operation, the cooling fan continues to run for a certain period afterwards.

Appliance door

If you open the appliance door during operation, the operation continues.

Condensation

Condensation can occur in the cooking compartment and on the appliance door when cooking. Condensation is normal and does not adversely affect appliance operation. Wipe away the condensation after cooking.

6 Accessories

Use original accessories. These have been made especially for your appliance.

Note: Heat may deform the accessory. This deformation has no effect on the function. When the accessory cools down, it will regain its original shape.

The accessories supplied may differ depending on the appliance model.

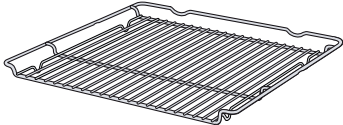
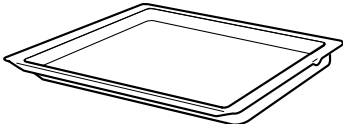
Accessories	Use
Wire rack 	<ul style="list-style-type: none"> ▪ Baking tins ▪ Ovenproof dishes ▪ Cookware ▪ Meat, e.g. roasting joints or steak ▪ Frozen meals
Universal pan 	<ul style="list-style-type: none"> ▪ Moist cakes ▪ Biscuits ▪ Bread ▪ Large roasts ▪ Frozen meals ▪ Catching dripping liquids, e.g. fat when grilling food on the wire rack.

Accessories

Baking tray

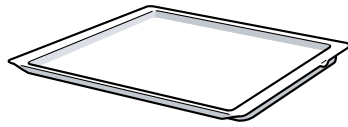

Use

- Tray bakes
- Sponge cake, simple

Espresso pot trivet



- Turkish coffee in the coffee pot
- Cooking with pans with a base smaller than 12 cm in diameter

6.1 Locking function

The locking function prevents the accessories from tilting when they are pulled out.

You can pull out the accessories approximately halfway without them tipping. The accessories must be inserted into the cooking compartment correctly for the tilt protection to work properly.

6.2 Sliding accessories into the cooking compartment

Always slide the accessory into the cooking compartment the right way round. This is the only way to ensure that accessories can be pulled out approximately halfway without tipping.

1. Turn the accessories so that the notch  is at the rear and is facing downwards.
2. Insert the accessory between the two guide rods for a shelf position.

Wire rack Insert the wire rack with the open side facing the appliance door and the curved lip  facing downwards.

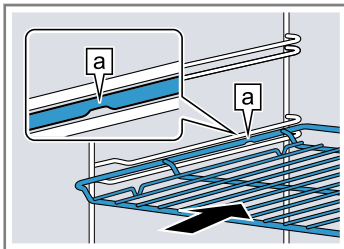

Tray E.g. universal pan or baking tray Slide the tray in with the sloping edge  towards the appliance door.

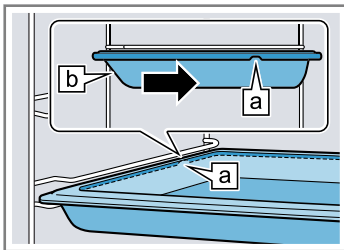

Espresso pot trivet Only use the attachment for espresso pots on the economy burner's wire rack.

3. Push the accessory all the way in, making sure that it does not touch the appliance door.

Note: Take any accessories that you will not be using out of the cooking compartment while the appliance is in operation.

Combining accessories

You can combine the wire rack with the universal pan to catch any liquid that drips down.

1. Place the wire rack on the universal pan so that both spacers  are on the rear edge of the universal pan.
2. Insert the universal pan between the two guide rods for a shelf position. In so doing, the wire rack is on top of the upper guide rod.

Wire rack on universal pan

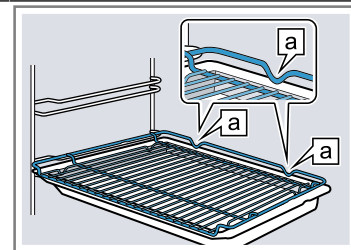

6.3 Other accessories

You can purchase other accessories from our customer service, specialist retailers or online.

You will find a comprehensive range of products for your appliance in our brochures and online:

www.bosch-home.com

Accessories are appliance-specific. When purchasing accessories, always quote the exact product number (E no.) of your appliance.

You can find out which accessories are available for your appliance in our online shop or from our customer service.

7 Before using for the first time

Configure the settings for initial start-up. Clean the appliance and accessories.

7.1 Initial configuration

Implement the settings for the initial configuration.

Setting the time

Once the appliance has been connected to the mains or after a power cut, the time flashes in the display. The time starts at "12:00". Set the current time.

Requirement: The function selector must be set to the off  position.

1. Use – or + to set the time.
2. Press .
- ✓ The time that is set appears in the display.

7.2 Cleaning the appliance before using it for the first time

Clean the cooking compartment and accessories before using the appliance to prepare food for the first time.

1. Remove the accessory and the leftover packaging, such as polystyrene pellets, from the cooking compartment.
2. Before heating, wipe the smooth surfaces in the cooking compartment with a soft, damp cloth.
3. Ventilate the room while the appliance is heating.

4. Set the type of heating and the temperature.
→ "Basic operation", Page 19

Type of heating	3D hot air 
Temperature	Maximum
Cooking time	1 hour

5. Switch off the appliance after the specified cooking time.
6. Wait until the cooking compartment has cooled down.
7. Clean the smooth surfaces with soapy water and a dish cloth.
8. Clean the accessory with soapy water and a dish cloth or a soft brush.

8 Cookware

This information has been provided to help you save energy and avoid damaging your cookware.

8.1 Using cookware

The selection and positioning of the cookware affects the safety and energy efficiency of your appliance.
→ "Saving energy", Page 8

WARNING – Risk of fire!

Flammable objects may ignite.

- ▶ Maintain a distance of at least 50 mm between the cookware and flammable objects.

Note: When using some items of cookware, a temporary, slight deformation of the stainless steel cooking surface may occur. This is normal and does not affect the functionality of the appliance.

Do not use deformed cookware. Only use cookware with a thick, flat base.	Deformed cookware is not stable on the hob and may tip over.
Place the cookware right in the centre of the burner.	The cookware may tip over if it is not placed in the centre of the burner.
Place the cookware correctly on the pan supports.	The cookware may tip over if you place it directly on the burner.

8.2 Suitable cookware

1. Only use cookware with a suitable diameter.
→ "Suitable cookware", Page 16
2. Ensure that the cookware does not protrude over the edge of the hob.

Suitable cookware

Only use cookware with a suitable diameter. The cookware must not protrude over the edge of the hob.

Burner/hotplate	Maximum diameter of the base of the cookware	Minimum diameter of the base of the cookware
High output burner	280 mm	240 mm
Standard output burner	240 mm	180 mm
Economy burner	180 mm	120 mm
Electric hotplate	145 mm	145 mm

9 Operating the hotplate

You can find out everything you need to know about operating your hotplate here.

9.1 Fitting burner parts

You can find out how to correctly position the burner parts here.

Requirement: Ensure that the burner parts are clean and dry.

1. Ensure that the individual parts of the burners are fitted in their exact position and are straight; otherwise,

this may result in ignition problems or problems during operation.

2. Position the burner lid precisely on the burner head.

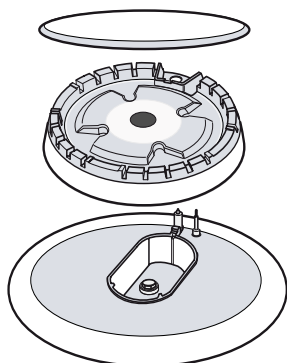

9.2 Important information about the gas hob

Follow these instructions when using your gas hob.

- A slight whistling when operating the burner is normal.
- Odour formation during the first uses is normal. This does not indicate a risk or malfunction. It will stop after a while.
- An orange flame is normal. This is caused by dust in the air, overflowing liquids, etc.
- If the burner's flame accidentally goes out, switch off the burner's selector and wait at least 1 minute before igniting the burner again.
- A few seconds after switching off the hob, you may hear noises, such as a slight clicking, from the burner. This is not unusual, but shows that the pilot is deactivated.
- Keep the ignition plugs clean. If the ignition plugs are dirty, the igniter is damaged. Clean the ignition plugs regularly with a small, metal-free brush. Ensure that the ignition plugs are not exposed to any heavy knocks.

9.3 Operating the hotplate

You can ignite the gas burner as follows.

⚠ WARNING – Risk of fire!

Escaping gas may ignite.

- ▶ If the burner does not ignite after 15 seconds, turn the control knob to the "Off" position and open the

door or window in the room. Do not attempt to re-ignite the burner for at least one minute.

- ▶ In the event of the burner flames being accidentally extinguished, turn off the burner control. Do not attempt to re-ignite the burner for at least one minute.

ATTENTION

The burner may not ignite or the burner flame is not even.

- ▶ Ensure that the hotplate burners are clean and dry.
- ▶ The burner cup and burner cover must be in exactly the right position.

The burner may go out accidentally.

- ▶ If the burner's flame accidentally goes out, switch off the burner's selector and wait at least one minute before igniting the burner again.

1. Place suitable cookware on the pan support.
→ "Suitable cookware", Page 16
2. Press and hold the selector for the required burner and set it to the ignition position ✱.
- ✓ The ignition process starts.
3. Press and hold the hotplate selector for approx. 1–3 seconds.
- ✓ The gas begins to flow out and the gas burner ignites.
- ✓ The safety pilot is therefore activated. If the gas flame goes out, the gas supply is automatically shut off by the safety pilot.
4. Set the desired flame size.
The flame is not stable between settings ◌ Off and ◐. You must therefore always choose a position between the ◐ large flame and ◑ small flame.
5. Check whether the flame is burning.
If the flame is not burning, repeat the steps.
6. To end the cooking process:
 - ▶ Turn the hotplate selector clockwise to ◌.

9.4 Manually igniting the appliance

Note: In the event of a power cut, you can light the burners manually.

1. Place suitable cookware on the pan support.
2. Push in the selector for your chosen burner and turn it anti-clockwise to the power level you require. Press and hold the selector.
3. Light the burner with a gas lighter or a match. Keep the selector pressed in for a few seconds after ignition.

9.5 Recommended cooking settings

You can find an overview of different foods with appropriate heat settings here.

Notes

- The cooking time will vary depending on the type, weight, thickness and quality of the food.
- Select the right cookware size for each hotplate. The diameter of the cookware base should be the same size as the hotplate.
- Use as little water as possible when cooking, so that the food retains its vitamins and minerals.
 - Use as little water as possible when cooking, so that the food retains its vitamins and minerals.
 - Select short cooking times so that the vegetables remain firm and full of nutrients.

Example	Food	Hotplate	Power level
Melting	Chocolate, butter, margarine	Economy burner	Small flame
Warming	Stock, tinned vegetables	Standard output burner	Small flame

Example	Food	Hotplate	Power level
Heating and keeping warm	Soups	Economy burner	Small flame
Steaming*	Fish	Standard output burner	Between large and small flame
Braising*	Potatoes and miscellaneous vegetables, meat	Standard output burner	Between large and small flame
Boiling*	Rice, vegetables, meat dishes (with sauces)	Standard output burner	Large flame
Frying	Pancakes, potatoes, schnitzel, fish fingers	Large burner** Wok burner**	Between large and small flame Between large and small flame

- Note**
Information
- * If you are using a pan with a lid, turn the flame down as soon as the food starts to boil.
 - ** Optional. Available for some appliances. Depending on the appliance type. (For frying on the wok burner, we recommend that you use a wok.)

10 Operating the electric hotplate

You can find out everything you need to know about operating your electric hotplate here.

10.1 Before using the electric hotplate for the first time

⚠ WARNING – Risk of harm to health!

When heating up the hotplate for the first time, vapours are released which may lead to irritation of the mucous membranes.

- ▶ The kitchen should therefore be well ventilated.
- ▶ Stay in the kitchen for a short time.
- ▶ Keep children, pets and particularly vulnerable people away from the room.

ATTENTION

If you operate the electric hotplate without cookware, this may lead to damage to the electric hotplate.

- ▶ Except for during initial heating, always operate the electric hotplate with cookware.

1. Ventilate the room while the electric hotplate is heating.
2. Switch off the electric hotplate after the specified cooking time.
3. Wait until the hotplate has cooled down.

10.2 Important information about the electric hotplate

Follow these instructions when using your electric hotplate.

- Do not switch on the electric hotplate without placing cookware on it.
- Only use cookware with a dry base. Avoid overflowing liquids and using wet cookware.
- Residual heat is present after the electric hotplate is switched off. Keep children at a safe distance.
- Ensure that the selector for the electric hotplate is switched off in the event of a power failure.
- We recommend that, at the beginning of the cooking process, you turn the selector to the highest level and

then select an intermediate position based on the quantity and consistency of the food.

- If the diameter of the cookware base does not correspond to the hotplate or if the cookware base is uneven, unnecessary energy is consumed. Use cookware with a thick, flat base, the diameter of which matches the diameter of the hotplate. Never use cookware with a smaller base.
- The hotplate can be switched off before the end of the cooking time in order to exploit the thermal inertia. To save energy, you can continue cooking for a while with the heat that has already been produced.
- Overflowing liquid is burnt on and leaves hard-to-remove stains. Use cookware with a suitable diameter in order to prevent an overflow.
- Due to the high heat effect, the metallic hotplate ring may discolour over time. Rectify the discolouration by cleaning the hotplate ring with the rough side of a sponge with washing-up liquid or abrasive cleaning agents. When cleaning, ensure that the sponge does not come into contact with the hotplate.
- If the surface of the electric hotplate is dirty as a result of long-term use, clean the surface with a few drops of oil or standard care products.

10.3 Switching on the electric hotplate

ATTENTION

If you operate the electric hotplate without cookware, this may lead to damage to the electric hotplate.

- ▶ Except for during initial heating, always operate the electric hotplate with cookware.

1. Place suitable cookware on the electric hotplate.
 2. While taking into consideration the cooking mode and the quantity of food as well as using the picture below as an aid, turn the selector anti-clockwise to a suitable position.
- ✓ The function display lights up.

10.4 Switching off the electric hotplate

Residual heat is present after the electric hotplate is switched off.

- ▶ Turn the selector to the 0 position.
- ✓ The function display goes out.

10.5 Recommended cooking settings

You can find an overview of different foods with appropriate heat settings here.

The cooking time will vary depending on the type, weight, thickness and quality of the food. Select the right cookware size for each hotplate. The diameter of the cookware base should be the same size as the hotplate.

Note

In these cases, increase the output:

- When cooking with larger quantities of liquid,
- When preparing larger quantities,
- When using cookware without a lid.

Power level	Cooking method	Examples
1-2	Melting	Butter, chocolate
2-3	Boiling	Rice, béchamel sauce and vegetable ragout
4-5	Boiling	Potatoes, pasta, vegetables
4-5	Searing	Ragout, roast joint
5	Steaming	Fish
2-3-4-5	Warming up and keeping the temperature of the food	Ready meals
6-7-8	Frying	Fillet, steak, börek
9	Boiling and frying	Meat

11 Basic operation

11.1 Switching on the appliance

- ▶ Turn the function selector to any position other than the "Off" position 0.
- ✓ The appliance is switched on.

11.2 Switching off the appliance

- ▶ Turn the function selector to the "Off" position 0.
- ✓ The appliance is switched off.

11.3 Types of heating and temperature

1. Use the function selector to set the type of heating.
2. Use the temperature selector to set the temperature or grill setting.
- ✓ The appliance starts heating after a few seconds.
3. When the dish is ready, switch off the appliance.

Tips

- The most suitable type of heating for your food can be found in the description of the types of heating.
- You can also set a cooking time and an end time on the appliance.
→ "Time-setting options", Page 20

Changing the type of heating

You can change the type of heating at any time.

- ▶ Use the function selector to set the required type of heating.

Changing the temperature

You can change the temperature at any time.

- ▶ Turn the temperature selector to set the desired temperature.

12 Rapid heating

To save time, you can use the rapid heating to shorten the preheat time.

Only use rapid heat-up when a temperature of over 100 °C has been set.

After rapid heating, it is best to use the following types of heating:

- 3D hot air 
- Top/bottom heating 

12.1 Setting rapid heating

To ensure an even cooking result, do not place the food in the cooking compartment until rapid heating has come to an end.

1. Use the function selector to select rapid heating .
2. Use the temperature selector to set the required temperature.
- ✓ Rapid heating starts after a few seconds.
- ✓ When the rapid heating process ends, an audible signal sounds and the heating indicator goes out.

- Use the function selector to set a suitable type of heating.





- Place the food in the cooking compartment.

13 Time-setting options

Your appliance has different time-setting options which ensure that operation can be controlled.

13.1 Overview of the time-setting options





You can use the  button to select the different time-setting options.



Time-setting option	Use
Timer 	The timer can be set independently of the operation. It does not affect the appliance.
Cooking time 	If a cooking time has been set for the operation, the appliance stops heating automatically once this time has elapsed.
End 	A time at which the operation ends can be set for the cooking time. The appliance starts up automatically so that it finishes cooking at the required time.
Time 	Set the time.

13.2 Setting the timer

The timer runs independently of the appliance when it is in operation. The timer can be set up to 23 hours and 59 minutes regardless of whether the appliance is on or off. The timer has its own audible signal so that you can tell whether it is the timer or a cooking time which has elapsed.

Note: The timer and cooking time cannot count down at the same time. If a cooking time has already been set, you cannot set the timer.

- Press  repeatedly until  is selected in the display.
- Use the  or  button to set the timer duration.

Button	Recommended value
	5 minutes
	10 minutes



Up to 10 minutes, the timer duration can be set in 30-second increments. The time increments become bigger as the value increases.

- ✓ The timer starts and the timer duration begins to count down after a few seconds.
 - ✓ An audible signal sounds and the timer duration is zero in the display when the timer duration has elapsed.
- Once the timer duration has elapsed
 - ▶ Press any button to switch off the timer.

Changing the timer

The timer duration can be changed at any time.



Requirement:  is highlighted in the display.

- ▶ Use the  or  button to change the timer duration.
- ✓ The appliance applies the change after a few seconds.

Cancelling the timer

The timer duration can be cancelled at any time.





Requirement:  is highlighted in the display.



- ▶ Use the  button to reset the timer duration to zero.
- ✓ After a few seconds, the appliance applies the change and  goes out.

13.3 Setting the cooking time

The cooking time can be set to up to 23 hours and 59 minutes for the operation.

Requirement: The type of heating and temperature or setting have been set.

- Press  repeatedly until  is selected in the display.
- Use the  or  button to set the cooking time.

Additional programme	Recommended value
	10 minutes
	30 minutes



The cooking time can be set in one-minute increments up to one hour, and then in five-minute increments.

- ✓ After a few seconds, the appliance starts heating and the cooking time counts down.
 - ✓ When the cooking time has elapsed, a signal sounds and the duration is at zero in the display.
- When the cooking time has elapsed:
 - ▶ Press any button to end the signal prematurely.
 - ▶ To set another cooking time, press the  button.
 - ▶ When the dish is ready, switch off the appliance.

Changing the cooking time

The cooking time can be changed at any time.

Requirement:  is highlighted in the display.

- ▶ Change the cooking time using the  or  button.
- ✓ The appliance applies the change after a few seconds.

Cancelling the cooking time

The cooking time can be cancelled at any time.

Requirement:  is highlighted in the display.

- ▶ Reset the cooking time to zero using the  button.
- ✓ After a few seconds, the appliance applies the change and continues to heat without a cooking time.

13.4 Setting the end time

You can delay the time at which the cooking time is due to end by up to 23 hours and 59 minutes.

Notes

- The end time cannot be set for types of heating with grill function.

- In order to achieve a good cooking result, do not delay the end time once the appliance is already operating.
- Food will spoil if you leave it in the cooking compartment for too long.

Requirements

- The type of heating and temperature or setting have been set.
 - A cooking time must be set.
1. Press  repeatedly until →I is selected in the display.
 2. Press the — or + button.
- ✓ The display shows the calculated end time.
3. Use the — or + button to delay the end time.
- ✓ After a few seconds, the appliance applies the setting and the display shows the set end time.
 - ✓ Once the calculated start time has been reached, the appliance starts heating up and the cooking time starts counting down.
 - ✓ When the cooking time has elapsed, a signal sounds and the duration is at zero in the display.
4. When the cooking time has elapsed:
 - ▶ Press any button to end the signal prematurely.
 - ▶ To set another cooking time, press the + button.
 - ▶ When the dish is ready, switch off the appliance.

Changing the end time

In order to achieve a good cooking result, you can only change the set end time before operation starts and the cooking time starts counting down.

Requirement: →I is highlighted in the display.

- ▶ Use the — or + button to delay the end time.
- ✓ The appliance applies the change after a few seconds.

Cancelling the end time

You can delete the set end time at any time.

Requirement: →I is highlighted in the display.

- ▶ Reset the end time to the current time plus the set cooking time using the — button.
- ✓ After a few seconds, the appliance applies the change and starts heating up. The cooking time counts down.

13.5 Setting the time

Once the appliance has been connected to the mains or after a power cut, the time flashes in the display. The time starts at "12:00". Set the current time.

Requirement: The function selector must be set to the off  position.

1. Use — or + to set the time.
 2. Press .
- ✓ The time that is set appears in the display.



14 Childproof lock

Secure the appliance to prevent children from accidentally switching it on or changing the settings.

Note: After a power cut, the childproof lock will no longer be active.

14.1 Activating and deactivating the childproof lock

Requirement: The function selector must be set to the off  position.

- ▶ To activate the childproof lock, press and hold the  button until *SAFE* appears in the display.
- ▶ To deactivate the childproof lock, press and hold the  button until *SAFE* goes out in the display.

15 Cleaning and servicing

15.1 Cleaning agent

To avoid damaging the different surfaces of the appliance, do not use unsuitable cleaning agents.

WARNING – Risk of electric shock!

An ingress of moisture can cause an electric shock.

- ▶ Do not use steam- or high-pressure cleaners to clean the appliance.

ATTENTION

Unsuitable cleaning agents damage the surfaces of the appliance.

- ▶ Do not use aggressive or abrasive cleaning agents.

Suitable cleaning agents

Only use cleaning agents that are suitable for the different surfaces on your appliance.

- ▶ Do not use cleaning products with a high alcohol content.
- ▶ Do not use hard scouring pads or cleaning sponges.
- ▶ Do not use any special cleaners if the appliance is still warm.

Using oven cleaner in a hot cooking compartment damages the enamel.

- ▶ Do not use oven cleaner in the cooking compartment when it is still warm.
- ▶ Remove all food remnants from the cooking compartment and the appliance door before you next heat up the appliance.

New sponge cloths contain residues from production.

- ▶ Wash new sponge cloths thoroughly before use.

Follow the instructions on cleaning the appliance.

→ "Cleaning the appliance", Page 23

Appliance

Surface	Suitable cleaning agents	Information
Stainless steel	<ul style="list-style-type: none"> ▪ Hot soapy water ▪ Special stainless steel cleaning products suitable for hot surfaces 	To prevent corrosion, remove any limescale, grease, starch or albumin (e.g. egg white) stains on stainless steel surfaces immediately. Apply a thin layer of the stainless steel cleaning product.
Enamel, plastic, painted, and screen-printed surfaces E.g. control panel	<ul style="list-style-type: none"> ▪ Hot soapy water 	Do not use a glass cleaning product or a glass scraper.
Knobs	<ul style="list-style-type: none"> ▪ Hot soapy water 	Clean with a dish cloth and dry with a soft cloth. Do not remove or scrub.
Gas hotplate burners and pan supports	<ul style="list-style-type: none"> ▪ Hot soapy water 	Clean the burner parts and pan support with a dish cloth. Only use a little water. Water must not be allowed to enter the inside of the appliance through the burner compartments. Do not clean in the dishwasher.
Electric hotplate	<ul style="list-style-type: none"> ▪ Hot soapy water 	Use a brush to remove heavy soiling. Briefly heat up the hotplate afterwards so that it dries.
Plinth drawer	<ul style="list-style-type: none"> ▪ Hot soapy water 	Clean with a dishcloth.

Appliance cover

Area	Suitable cleaning agents	Information
Door panels	<ul style="list-style-type: none"> ▪ Hot soapy water 	Do not use a glass scraper or steel wool. Tip: Remove the door panels in order to clean them thoroughly. → "Appliance door", Page 26
Door cover	<ul style="list-style-type: none"> ▪ Made of stainless steel: Stainless steel cleaner: ▪ Made of plastic: Hot soapy water 	Do not use a glass cleaning product or a glass scraper. Tip: To thoroughly clean the cover plate, remove the cover. → "Appliance door", Page 26
Door handle	<ul style="list-style-type: none"> ▪ Hot soapy water 	In order to avoid stubborn dirt, remove descaling agents from the door handle immediately.
Door seal	<ul style="list-style-type: none"> ▪ Hot soapy water 	Do not remove or scrub.

Hob

Area	Suitable cleaning agents	Information
Enamelled surfaces	<ul style="list-style-type: none"> ▪ Hot soapy water ▪ Vinegar solution ▪ Oven cleaner 	Soak any heavily soiled areas and use a brush or steel wool. Leave the appliance cover open so that the hob can dry after it has been cleaned. Notes <ul style="list-style-type: none"> ▪ Enamel burns at very high temperatures, causing minor discolouration. The functionality of the appliance is not affected by this. ▪ The edges of thin baking trays cannot be completely enamelled and may be rough. This does not impair the corrosion protection. ▪ Food residues leave a white coating on the enamelled surfaces. The coating does not pose a health risk. The functionality of the appliance is not affected by this. You can remove these residues with lemon juice.
Self-cleaning surfaces	-	Follow the instructions for self-cleaning surfaces. → "Cleaning self-cleaning surfaces in the cooking compartment", Page 23
Glass cover on the oven light	<ul style="list-style-type: none"> ▪ Hot soapy water 	Use oven cleaner to remove very heavy soiling.
Rails	<ul style="list-style-type: none"> ▪ Hot soapy water 	Soak any heavily soiled areas and use a brush or steel wool.

Area	Suitable cleaning agents	Information
Accessories	<ul style="list-style-type: none"> ■ Hot soapy water ■ Oven cleaner 	<p>Tip: Remove the shelf supports for cleaning. → "Rails", Page 25</p> <p>Soak any heavily soiled areas and use a brush or steel wool. Enamelled accessories are dishwasher-safe.</p>

15.2 Cleaning the appliance

In order to avoid damaging the appliance, clean your appliance only as specified, and using suitable cleaning products.

⚠ **WARNING – Risk of burns!**

The appliance and its parts that can be touched become hot during use.

- ▶ Caution should be exercised here in order to avoid touching heating elements.
- ▶ Young children under 8 years of age must be kept away from the appliance.

⚠ **WARNING – Risk of fire!**

Loose food remnants, fat and meat juices may catch fire.

- ▶ Before using the appliance, remove the worst of the food residues and remnants from the cooking compartment, heating elements and accessories.

Requirement: Read the information on cleaning agents.

→ "Cleaning agent", Page 21

1. Clean the appliance using hot soapy water and a dish cloth.
 - ▶ For some surfaces, you can use alternative cleaning agents.
→ "Suitable cleaning agents", Page 21
2. Dry with a soft cloth.

15.3 Cleaning controls

⚠ **WARNING – Risk of electric shock!**

An ingress of moisture can cause an electric shock.

- ▶ Do not detach the control knobs to clean them.
 - ▶ Do not use wet sponge cloths.
1. Observe the information regarding the cleaning agents.
 2. Clean using a damp sponge cloth and hot soapy water.
 3. Dry with a soft cloth.

15.4 Cleaning self-cleaning surfaces in the cooking compartment

The back wall in the cooking compartment is self-cleaning. The self-cleaning surfaces are coated with a porous, matt ceramic layer and have a rough surface. When the appliance is in operation, the self-cleaning surfaces absorb splashes from roasting or grilling and break them down. If the self-cleaning surfaces no longer clean sufficiently during operation, heat up the cooking compartment specifically.

ATTENTION

If the self-cleaning surfaces are not cleaned regularly, the surfaces may be damaged.

- ▶ If dark spots can be seen on the self-cleaning surfaces, heat up the cooking compartment.

- ▶ Do not use any oven cleaners or abrasive cleaning aids. If oven cleaner accidentally comes into contact with the self-cleaning surfaces, dab the surfaces immediately with water and a sponge cloth. Do not rub them.

1. Remove the accessories and cookware from the cooking compartment.
2. Detach the shelf supports and remove them from the cooking compartment.
→ "Rails", Page 25
3. Clean coarse dirt with hot soapy water and a soft cloth:
 - From the smooth enamel surfaces
 - From the inside of the appliance cover
 - From the glass cover on the oven lamp
 This prevents stubborn stains.
4. Remove any objects from the cooking compartment. The cooking compartment must be empty.
5. Use the function selector to set **3D hot air**.
6. Use the temperature selector to set the maximum temperature.
 - ✓ The appliance starts heating after a few seconds.
7. Switch off the appliance after 1 hour.
8. Once the appliance has cooled down sufficiently, wipe the cooking compartment with a damp cloth.

Note: Reddish marks may appear on the self-cleaning surfaces. This is not rust, but the residues of salty food. Nutrients such as sugars and proteins are not removed from the surface coating and may stick to the surface. These spots are not harmful and do not impair the cleaning ability of the self-cleaning surfaces.
9. Attach the shelf supports.
→ "Rails", Page 25

15.5 Discoloration of the burners

After long use, the brass burner parts become darker due to natural oxidation. This discolouration does not affect their usability.

15.6 Cleaning the pan support manually

⚠ **WARNING – Risk of burns!**

The appliance becomes hot during operation.

- ▶ Allow the appliance to cool down before cleaning.
1. Carefully remove the pan support.
 2. Soak the pan support in the sink.
 3. Clean the pan support using a scrubbing brush and washing-up liquid.
 4. Rinse the pan support with clean water.
 5. Dry the pan support with a kitchen towel.

15.7 Using cleaning gel for burnt-on dirt

For hard-to-remove, burnt-on dirt, you can order a cleaning gel from our online shop, from your specialist retailer or via our after-sales service.

1. Follow the instructions on the cleaning product.
 2. Remove the pan supports and the burner parts.
 3. **ATTENTION** – On the burner parts, the controls and the aluminium surfaces, the cleaning gel leads to damage.
 - ▶ Only use the cleaning gel on the pan supports and stainless steel surfaces.
- Apply the cleaning gel to the burnt-on dirt.
4. If necessary, let the dirt soak overnight.

15.8 Cleaning the stainless steel surfaces

1. Observe the information regarding the cleaning agents.
2. Clean using a sponge cloth and hot soapy water in the direction of the finish.
3. Dry with a soft cloth.
4. Apply a thin layer of the stainless steel cleaning product with a soft cloth.

Tip: You can obtain stainless steel cleaning products from after-sales service or the online shop.

15.9 Cleaning the burners

⚠ **WARNING – Risk of burns!**

The appliance becomes hot during operation.

- ▶ Allow the appliance to cool down before cleaning.

Note: After a long period of use, the brass burner parts become darker due to natural oxidation. This discolouration does not affect their usability.

1. Carefully remove the pan support.
2. Carefully remove the burner parts.
3. Clean the burner parts using a scrubbing brush and washing-up liquid.

4. Rinse the burner parts with clean water.
5. Ensure that the burner parts are completely dry before fitting them; otherwise, there may be ignition problems or problems during operation.

15.10 Cleaning the electric hotplate

If the surface of the electric hotplate is dirty as a result of long-term use, clean the surface with a few drops of oil or standard care products.

⚠ **WARNING – Risk of burns!**

The appliance becomes hot during operation.

- ▶ Allow the appliance to cool down before cleaning.

1. Clean the electric hotplate using a scrubbing brush and washing-up liquid.
2. Briefly heat up the hotplate afterwards so that it dries. Wet plates rust over time.
3. **Note:** Due to the high heat effect, the metallic hotplate ring may discolour over time. Rectify the discolouration by cleaning the hotplate ring with the rough side of a sponge with washing-up liquid or abrasive cleaning agents. When cleaning, ensure that the sponge does not come into contact with the hotplate.

15.11 Cleaning the cooking zone switch

Clean the cooking zone switch after use if it is dirty or stained.

Note

- Read the information on unsuitable cleaning agents.
 - Do not use a glass scraper.
 - Do not use a glass ceramic cleaner.
 - Do not remove the cooking zone switch.
1. Clean the cooking zone switch using hot soapy water and a soft cloth.
 - Wring out the cloth well. The cloth must not be too wet.
 - Wash new sponge cloths thoroughly before use.
 2. Dry with a soft cloth.

16 Cleaning aid

The cleaning aid is a fast alternative for occasionally cleaning the cooking compartment. The cleaning aid evaporates soapy water and therefore softens dirt. This means that dirt can be removed more easily.

16.1 Setting the cleaning aid

⚠ **WARNING – Risk of scalding!**

If there is water in the cooking compartment when it is hot, this may create hot steam.

- ▶ Never pour water into the cooking compartment when the cooking compartment is hot.

Requirement: The cooking compartment must be cooled down completely.

1. Remove the accessories from the cooking compartment.
2. Add one drop of detergent to 0.4 l water and pour it onto the centre of the cooking compartment floor. Do not use distilled water.

3. Use the function selector to set the **Bottom heating** type of heating.
4. Use the temperature selector to set 80 °C.
5. Press  repeatedly until I→I is selected in the display.
6. Use – or + to set the duration to four minutes.
 - ✓ After a few seconds, the appliance starts heating and the duration counts down.
 - ✓ When the cooking time has counted down, a signal sounds and the duration is at zero in the display.
7. Switch off the appliance and leave it to cool for approx. 20 minutes.

16.2 Cleaning the cooking compartment after using it

ATTENTION

If the cooking compartment remains damp for too long, this results in corrosion.

- ▶ After using the cleaning aid, wipe the cooking compartment and allow it to dry completely.

Requirement: The cooking compartment has cooled down.

1. Open the appliance door and absorb the residual water with an absorbent sponge cloth.
2. Clean smooth surfaces in the cooking compartment with a dish cloth or a soft brush. Remove stubborn residues with a stainless steel spiral scourer.

3. Remove limescale deposits using a vinegar-soaked cloth. Wipe this away with clear water and use a soft cloth to also rub underneath the door seal dry.
4. Once the cooking compartment is sufficiently clean:
 - ▶ In order to cool the cooking compartment, leave the appliance door open in the detent position for approx. one hour.
 - ▶ To dry the cooking compartment more quickly, heat up the appliance with the door open with **3D hot air**  and 50 °C for approx. five minutes.

17 Rails

To clean the rails and cooking compartment thoroughly, you can remove the shelf supports.

17.1 Unhooking the rails

 **WARNING – Risk of burns!**

The rails can be very hot.

- ▶ Never touch the rails when they are hot.
- ▶ Allow the appliance to cool down.
- ▶ Keep children at a safe distance.

1. Hold the bottom of the shelf support and pull it slightly towards the front. Pull the extension pins in the lower section of the rails out of the mounting openings.

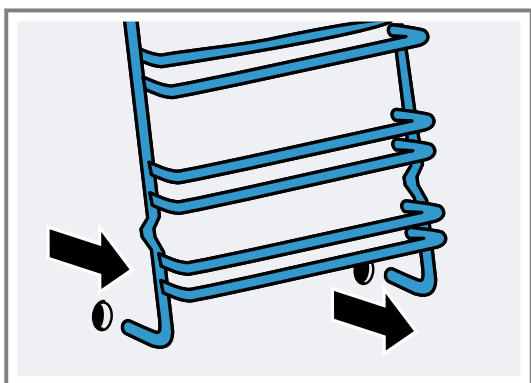

2. Pull the entire shelf support downwards first and then pull it forwards and remove it.

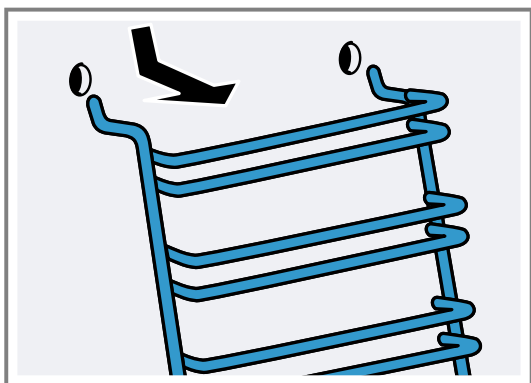

17.2 Attaching the rails

1. Place the two hooks at the top of the rail into the upper holes.

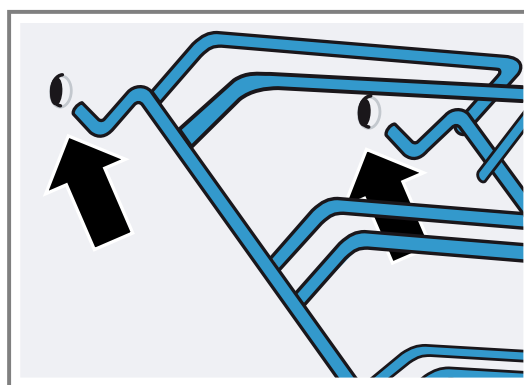

2. **ATTENTION – Incorrect assembly**

- ▶ Never move the rail before the two hooks are secured fully in the upper holes. Otherwise the enamelled coating may be damaged and break.

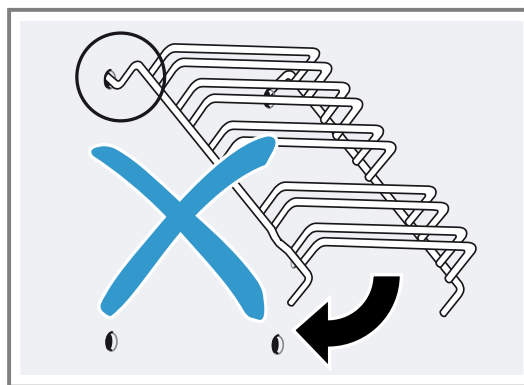

- Both hooks must be inserted fully into the upper holes. Move the rail down slowly and carefully, and hook it into the lower holes.

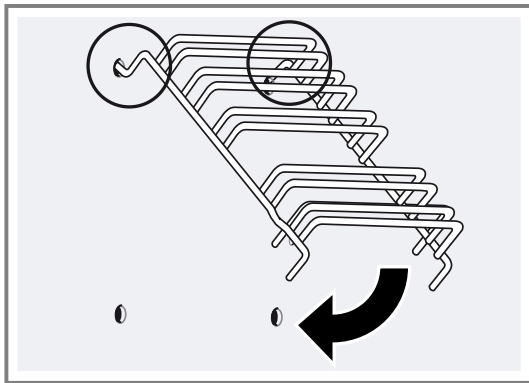

- Hook both rails into the side walls of the oven.

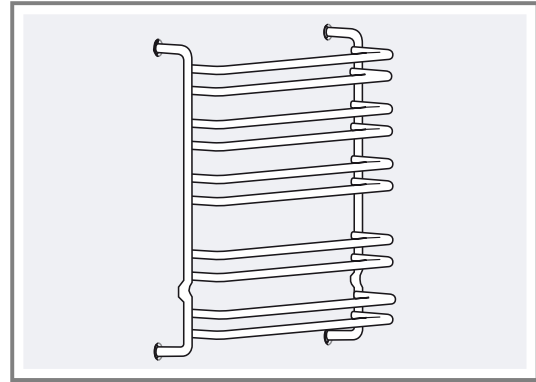

If the rails are fitted correctly, the distance between the two upper shelf positions is greater.

18 Appliance door

It is normally sufficient if you clean the outside of the appliance door. If the appliance door is very dirty on the inside and outside, you can remove the appliance door and clean it.

18.1 Door hinges

⚠ WARNING – Risk of injury!

When the hinges are not secured, they can snap shut with great force.

- ▶ If you open the appliance door, ensure that the locking levers are fully open or fully closed.

- The oven door hinges each have a locking lever. When the locking levers are closed, the oven door is secured in place.

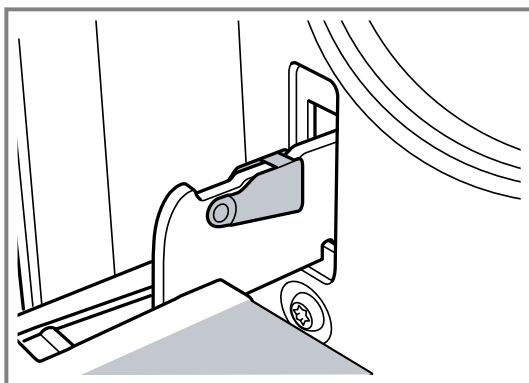

It cannot be detached.

- When the locking levers are open in order to detach the oven door, the hinges are secured.

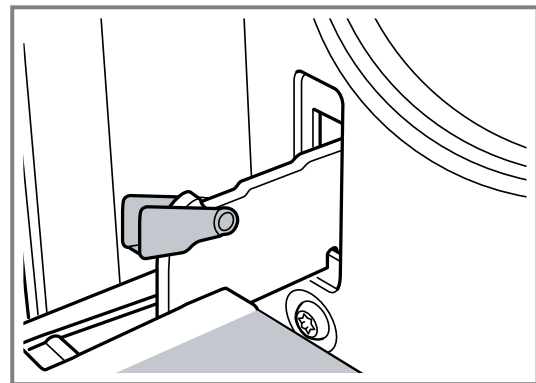

The hinges cannot snap shut.

18.2 Removing the appliance door

- Open the oven door fully.
- Open the locking levers on the left- and right-hand hinges.

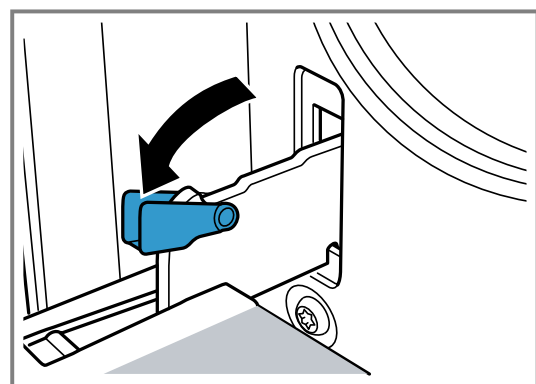

3. Close the oven door as far as the limit stop. Grip the left and right hand sides of the door with both hands. Close the door slightly more and remove it.

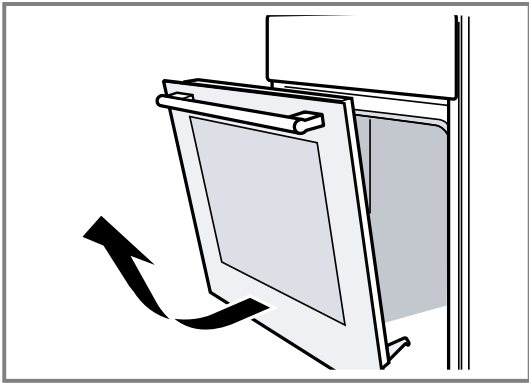

18.3 Removing the door panes

The glass panes of the oven door can be removed to make cleaning easier.

⚠ WARNING – Risk of injury!

Scratched glass in the appliance door may develop into a crack.

- ▶ Do not use any harsh or abrasive cleaners or sharp metal scrapers to clean the glass on the oven door, as they may scratch the surface.

The components in the appliance door may have sharp edges.

- ▶ Wear gloves.

1. Detach the oven door.
→ "Removing the appliance door", Page 26
2. Position it on a cloth with its handle pointing downwards.
3. To remove the upper cover of the oven door, press in the tabs on the left and right using your fingers. Pull out and remove the cover.

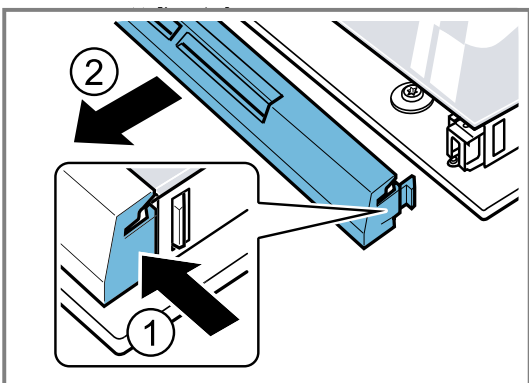

4. Lift the top pane up and out.

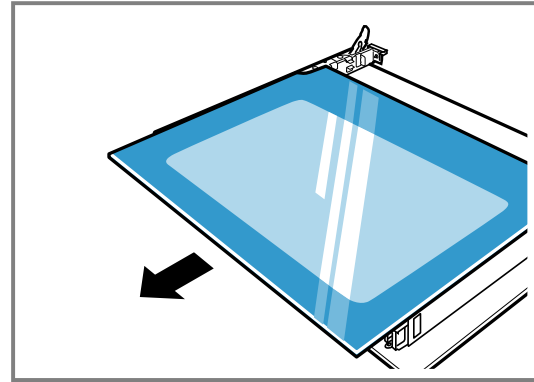

18.4 Fitting the door panes

1. Hold the top pane firmly on both sides and insert it at an angle towards the back.

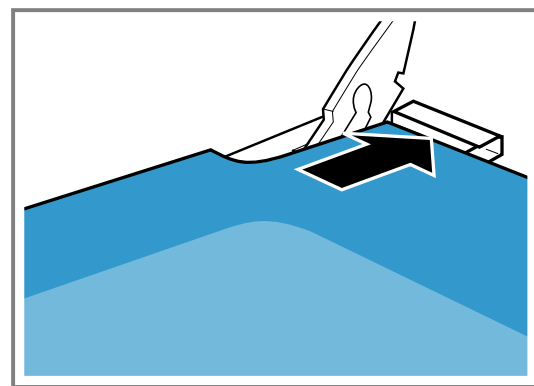

Push the pane into both openings on the underside. The smooth surface must face outwards and the rough surface must face inwards.

2. Place the cover at the top of the oven door and press it on. The mounting brackets must lock in place on both sides.
3. Attach the oven door.
→ "Attaching the appliance door", Page 27

Note: Only use the oven once the glass panes have been correctly fitted.

18.5 Attaching the appliance door

Reattach the oven door in the reverse sequence to removal.

⚠ WARNING – Risk of injury!

The oven door might accidentally fall or a hinge may suddenly snap shut.

- ▶ In this case, do not hold onto the hinge. Call customer service.

1. When attaching the oven door, ensure that both hinges are inserted in the opening direction.

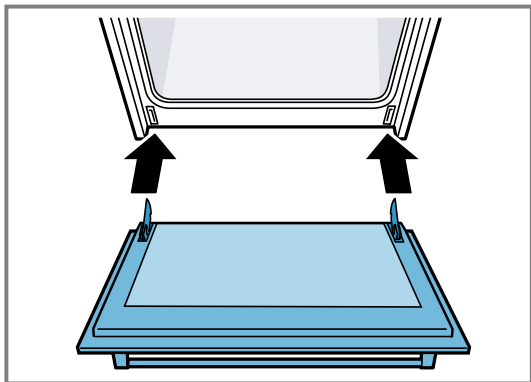

2. The notch on the hinge must engage on both sides.

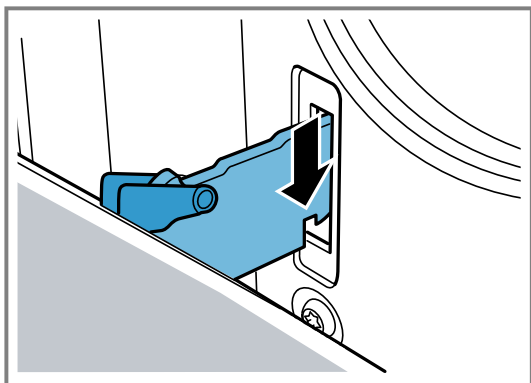

3. Close both locking levers again.

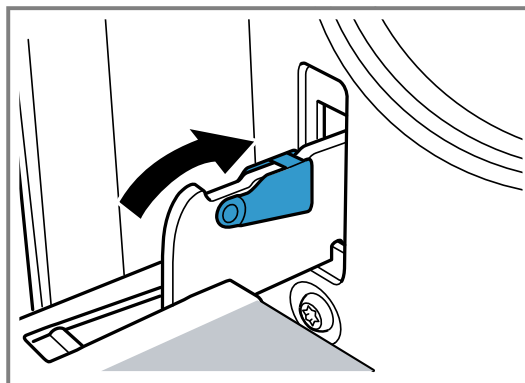

4. Close the appliance door.

18.6 Additional door safety

Additional safety devices have been fitted to prevent contact with the oven doors. Always attach these safety devices when children could come near the oven. You can purchase this special accessory from after-sales service. 11023590

⚠ WARNING – Risk of burns!

During long cooking times, the oven door may become very hot.

- ▶ Supervise small children when the oven is in operation.

19 Troubleshooting

You can rectify minor faults on your appliance yourself. Read the troubleshooting information before contacting after-sales service. This will avoid unnecessary costs.

⚠ WARNING – Risk of injury!

Improper repairs are dangerous.

- ▶ Repairs to the appliance should only be carried out by trained specialist staff.
- ▶ If the appliance is defective, call Customer Service.
→ "Customer Service", Page 30



⚠ WARNING – Risk of electric shock!

Improper repairs are dangerous.

- ▶ Repairs to the appliance should only be carried out by trained specialist staff.
- ▶ Only use genuine spare parts when repairing the appliance.
- ▶ If the power cord of this appliance is damaged, it must be replaced by the manufacturer, the manufacturer's Customer Service or a similarly qualified person in order to prevent any risk.

19.1 Malfunctions

Fault	Cause and troubleshooting
The appliance is not working.	The mains plug of the power cord is not plugged in.
	▶ Connect the appliance to the power supply.
	The circuit breaker in the fuse box has tripped.
	▶ Check the circuit breaker in the fuse box.
	There has been a power cut.
	▶ Check whether the lighting in your room or other appliances are working.

Fault	Cause and troubleshooting
The appliance does not switch off fully at the end of a cooking time.	<p>At the end of a cooking time, the appliance stops heating up. The oven light and cooling fan do not switch off. For types of heating with air recirculation, the fan continues to run in the back wall of the cooking compartment.</p> <ul style="list-style-type: none"> ▶ Turn the function selector to the off position. ✓ The appliance is switched off. ✓ The oven light and the fan in the back wall are switched off. ✓ The cooling fan switches off automatically as soon as the appliance has cooled down.
The time flashes in the display.	<p>There has been a power cut.</p> <ul style="list-style-type: none"> ▶ Reset the time. <p>→ <i>"Setting the time", Page 21</i></p>
5 R F E lights up in the display and no settings can be made on the appliance.	<p>Childproof lock is activated.</p> <ul style="list-style-type: none"> ▶ Use  to deactivate childproof lock. <p>→ <i>"Childproof lock", Page 21</i></p>
A message with E appears in the display, e.g. E05-32.	<p>Electronics fault</p> <ol style="list-style-type: none"> 1. Press . ▶ If necessary, reset the time on the clock. ✓ If the fault was a one-off, the error message disappears. 2. If the error message appears again, call the after-sales service. State the exact error message and the E no. for your appliance in full. <p>→ <i>"Customer Service", Page 30</i></p>
There is a smell of gas in the kitchen.	<p>The gas cylinder connection is leaking.</p> <ol style="list-style-type: none"> 1. Ventilate the room. 2. Check the gas cylinder connection. <hr/> <p>The gas pipe to the appliance is leaking.</p> <ol style="list-style-type: none"> 1. Ventilate the room. 2. Call the gas supplier.
Burner does not ignite.	<p>There has been a power cut.</p> <ul style="list-style-type: none"> ▶ Light the burner with a gas lighter or a match. <hr/> <p>The burner parts are positioned incorrectly.</p> <ol style="list-style-type: none"> 1. Position the burner parts precisely and evenly. 2. Ensure that the locking catches click into place in the recesses. <hr/> <p>Burner parts are wet.</p> <ul style="list-style-type: none"> ▶ Carefully dry the burner parts. <hr/> <p>Food remnants or dirt are located between the ignition plug and the burner.</p> <ul style="list-style-type: none"> ▶ Clean the space between the ignition plugs and burners. <hr/> <p>The safety valve for the gas line is closed.</p> <ul style="list-style-type: none"> ▶ Open the safety valve for the gas line. <hr/> <p>Gas cylinder is empty.</p> <ul style="list-style-type: none"> ▶ Replace the gas cylinder. <hr/> <p>There is air in the gas line following initial connection or a cylinder change.</p> <ol style="list-style-type: none"> 1. Turn the control knob to 0. 2. Ignite the burner again. 3. If necessary, repeat the ignition several times.
Burner goes out straight after being ignited.	<p>The control knob was not held down for long enough.</p> <ol style="list-style-type: none"> 1. Keep the control knob pressed in for a few seconds after ignition. 2. Push the control knob in firmly. <hr/> <p>Openings on the burner are soiled.</p> <ul style="list-style-type: none"> ▶ Clean and dry the openings on the burner.
The burner flame is not uniform.	<p>The burner parts are positioned incorrectly.</p> <ol style="list-style-type: none"> 1. Position the burner parts precisely and evenly. 2. Ensure that the locking catches click into place in the recesses. <hr/> <p>Openings on the burner are soiled.</p> <ul style="list-style-type: none"> ▶ Clean and dry the openings on the burner.
The burner flame goes out while the appliance is in operation.	<p>Gas cylinder is empty.</p> <ul style="list-style-type: none"> ▶ Replace the gas cylinder.

19.2 Replacing the oven light bulb

If the light in the cooking compartment fails, change the oven light bulb.

Note: Heat-resistant, 40 - 43-watt, 230 V halogen bulbs are available from the after-sales service or specialist retailers. Only use these bulbs. Hold the new halogen bulbs only with a clean, dry towel. This increases the service life of the bulb.

⚠ **WARNING – Risk of burns!**

The appliance and its parts that can be touched become hot during use.

- ▶ Caution should be exercised here in order to avoid touching heating elements.
- ▶ Young children under 8 years of age must be kept away from the appliance.

⚠ **WARNING – Risk of electric shock!**

When changing the bulb, the bulb socket contacts are live.

- ▶ Before replacing the bulb, ensure that the appliance is switched off in order to prevent a potential electric shock.

Requirements

- The appliance is disconnected from the power supply.
- The cooking compartment has cooled down.

- You must have a new halogen lamp to replace the old one.
1. Place a tea towel in the cooking compartment to prevent damage.
 2. Turn the glass cover anti-clockwise.
 3. Pull out the halogen bulb without turning it.

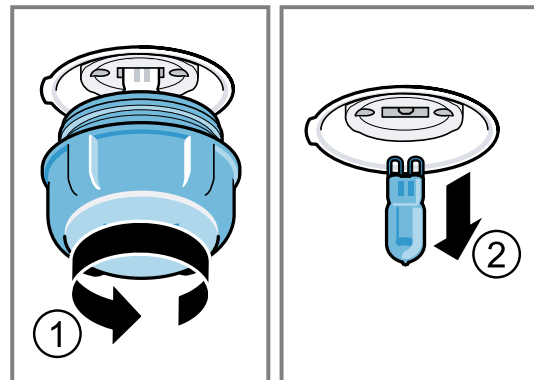

4. Insert the new halogen bulb and press it firmly into the socket. Make sure that the pins are positioned correctly.
5. Depending on the appliance model, the glass cover may have a sealing ring. Attach the sealing ring.
6. Screw in the glass cover.
7. Remove the tea towel from the cooking compartment.
8. Connect the appliance to the power supply.

20 Transportation and disposal

You can find out here how to prepare your appliance for transportation. You will also find out how to dispose of old appliances.

20.1 Disposing of old appliance

Valuable raw materials can be reused by recycling.

1. Unplug the appliance from the mains.
2. Cut through the power cord.
3. Dispose of the appliance in an environmentally friendly manner.

Information about current disposal methods are available from your specialist dealer or local authority.



This appliance is labelled in accordance with European Directive 2012/19/EU concerning used electrical and electronic appliances (waste electrical and electronic equipment - WEEE). The guideline determines the framework for the return and recycling of used appliances as applicable throughout the EU.

20.2 Transporting the appliance

Keep the original appliance packaging. Only transport the appliance in the original packaging. Observe the transport arrows on the packaging.

1. Secure all moving parts in and on the appliance using adhesive tape that can be removed without leaving any traces.
2. Slide all accessories, such as baking trays, into the corresponding slots with thin cardboard at the edges, in order to avoid damaging the appliance.
3. Place cardboard or similar between the front and rear side to prevent knocks against the inside of the door glass.
4. Secure the door and, if available, the top cover to the appliance sides using adhesive tape.

If the original packaging is no longer available

1. In order to guarantee sufficient protection against any transport damage, pack the appliance in protective packaging.
2. Always transport the appliance upright.
3. Do not hold the appliance by the door handle or the connections on the rear, as these could be damaged.
4. Do not place any heavy objects on the appliance.

21 Customer Service

Function-relevant genuine spare parts according to the corresponding Ecodesign Directive can be obtained from Customer Service for a period of at least 10 years

from the date on which your appliance was placed on the market within the European Economic Area.

Furthermore, our Customer Service will continue to provide you with other function-relevant and storable genuine spare parts for up to 15 years from the date on which your appliance was placed on the market.

For more information, please contact our Customer Service team.

Detailed information about the warranty period and the warranty conditions in your country is available via the QR code on the enclosed document on service contacts and warranty conditions, from our customer service or on our website.

You can find the contact details for our customer service via the QR code on the enclosed document on service contacts and warranty conditions or on our website.

This product contains light sources from energy efficiency class G.

21.1 Product number (E-Nr.) and production number (FD)

If you contact Customer Service, you will require the product number (E-Nr.) and the production number (FD), which you can find on the appliance's rating plate. You will see the rating plate with these numbers if you open the appliance door.

Make a note of your appliance's details and the Customer Service telephone number to find them again quickly.

22 How it works

Here, you can find the ideal settings for various types of food as well as the best accessories and cookware.

These recommendations are perfectly tailored to your appliance.

Detailed baking tables for your appliance and tips for baking with your appliance can be found in the instructions on the Internet:

www.bosch-home.com

22.1 Cooking tips

Observe this information when preparing food.

- The temperature and cooking time depend on the amount of food and the recipe. Settings ranges are specified for this reason. Select the lower value first.
- The setting values apply to food placed in the cooking compartment while the cooking compartment is still cold.
Do not place accessories into the cooking compartment until it has finished preheating.
- Remove any accessories that are not being used from the cooking compartment.
- Ensure that the accessory slides in the right way round.

22.2 Notes on baking

When baking, use the shelf positions indicated.

Baking on one level	Shelf position
Rising pasta/baked goods or tin on the wire rack	2
Flat pasta/baked items or in the baking tray	2–3
Baking on two or more levels	Shelf position
Universal pan	3
Baking tray	1
Baking tins on the wire rack:	Shelf position
First wire rack	3
Second wire rack	1

Baking on three levels	Shelf position
Baking trays	5
Universal pan	3
Baking trays	1

Notes

- When baking on several layers, use hot air. Different food that is placed in the oven at the same time will not necessarily be ready at the same time.
In such cases, you can remove the cooked food and continue to cook the other baking tray. If necessary, you can change the position and direction of the baking trays.
- Place dishes next to each other or offset one above the other in the cooking chamber. You can cut energy use by cooking different items at the same time.
- For best results, we recommend using dark-coloured metal baking tins.

22.3 Notes on roasting and grilling

The setting values are based on the assumption that unstuffed, chilled, ready-to-roast poultry, meat or fish is placed into a cold cooking compartment.

ATTENTION

Acidic food may damage the wire rack

- ▶ Do not place acidic food, such as fruit or food with an acidic marinade directly on the wire rack.
- The larger the poultry, meat or fish, the lower the temperature and the longer the cooking time.
- Turn the poultry, meat or fish after approx. 1/2 to 2/3 of the time listed.
- Add a little liquid to the poultry in the cookware.
Cover the base of the cookware with approx. 1–2 cm of liquid.
- When you turn poultry, ensure that the breast side or skin side is underneath to begin with.
- Use tongs to turn the pieces of food you are grilling. If you pierce the meat with a fork, the juices will run out and it will become dry.
- Only add salt to steaks once they have been grilled.
Salt draws water from the meat.

Information for those allergic to nickel

In rare cases, small amounts of nickel may pass into the food.

22.4 List of foods

Food	Accessories/cook-ware	Shelf posi-tion	Type of heating	Temperature in °C/grill setting	Cooking time in mins
Sponge cake, simple	Vienna ring tin/loaf tin	2		160–180	50–60
Sponge cake, simple, 2 levels	Vienna ring tin/loaf tin	3+1		140–160	60–80
Fruit tart or cheesecake with shortcrust pastry base	Springform cake tin, diameter 26 cm	2		160–180	70–90
Sponge flan, 6 eggs	Springform cake tin Ø 28 cm	2		160–170	35–45
Swiss roll	Universal pan	2		170–190 ¹	15–20
Shortcrust tart with moist topping	Universal pan	2		160–180	60–90
Muffins	Muffin tray on wire rack	2		170–190	20–40
Small baked items, with yeast	Universal pan	3		150–170	25–35
Biscuits	Universal pan	3		140–160	20–30
Biscuits, 2 levels	Universal pan + Baking tray	3+1		130–150	25–35
Biscuits, 3 levels	2x Baking tray + Universal pan	5+3+1		130–150	30–40
Bread, 1000 g, in a loaf tin or free-form	Universal pan or Loaf tin	2		200–220	35–50
Pizza, fresh	Universal pan	3		170–190	20–30
Pizza, fresh, thin-crust	Universal pan	2		250–270 ¹	15–25
Quiche, flan	Tart dish or tin	2		190–210	35–45
Bake, savoury, fresh, cooked ingredi-ents	Ovenproof dish	2		200–220	30–60
Chicken, 1.3 kg, unstuffed	Cookware without lid	2		200–220	60–70
Small chicken portions, 250 g each	Cookware without lid	3		220–230	30–35
Goose, unstuffed, 3 kg	Cookware without lid	2		170–190	120–140
Fillet of beef, medium, 1 kg	Cookware without lid	3		210–220	45–55
Pot-roasted beef, 1.5 kg	Cookware with lid	2		200–220	100–120 ²
Sirloin, medium, 1.5 kg	Cookware without lid	2		200–220	60–70
Hamburger, 3–4 cm thick	Wire rack	4		3 ³	25–30 ⁴
Leg of lamb, boned, medium, 1.5 kg	Cookware without lid	2		170–190	70–80 ⁵
Fish, grilled, whole, 300 g, e.g. trout	Wire rack	2		2	20–25 ⁴

22.5 Yoghurt

You can also use your appliance to make your own yoghurt.

Making yoghurt

1. Remove the accessories and shelves from the cooking compartment.

2. Heat 1 litre of milk (3.5% fat) to 90 °C on the hob and then leave it to cool down to 40 °C. Only heat UHT milk to 40 °C.

3. Stir 30 g yoghurt into the milk.

4. Pour the mixture into small containers, e.g. small jars with lids.

5. Cover the containers with film, e.g. cling film.

6. Place the containers on the cooking compartment floor.

¹ Preheat the appliance.

² At the start, add liquid to the cookware so that at least 2/3 of the joint is covered in liquid

³ Turn the dish 2/3 of the way through the cooking time.

⁴ Slide the universal pan underneath the wire rack.

⁵ Do not turn the food. Cover the base with water.

7. Use the recommended settings when configuring the appliance settings.

8. After making the yoghurt, leave it to cool in the refrigerator.

Yoghurt

Meal	Accessory/cookware	Shelf position	Type of heating/function	Temperature in °C	Cooking time, minutes
Yoghurt	Cup/jar	Cooking compartment floor	☼	-	4–5 hours

23 Installation instructions

The installation instructions contain instructions for the gas connection and for the gas conversion's assembly.

Note: For after-sales service only.



← mm →

23.1 General information

Your appliance must only be converted from one gas type to another by authorised personnel who have received appropriate training. The procedure must always be carried out in accordance with the instructions in this manual.

Incorrect connection and incorrect settings may damage the appliance. The appliance manufacturer shall accept no liability for incorrect connections or incorrect settings.

- Wear protective gloves so that you do not cut yourself. Accessible parts may have sharp edges.
- Do not place the appliance behind a decorative door or the door of a kitchen unit. There is a risk of overheating.
- Never install the appliance in boats or in vehicles.
- Always closely observe the symbols on the rating plate. If there is no symbol that is relevant to your country, comply with the technical guidelines in force in your country when configuring the appliance settings.
- Find out which gas type and which gas pressure your local gas supply network uses before installing the appliance. Before using the appliance, ensure that all settings have been set correctly.
- Always comply with local and national guidelines and regulations.

- The settings for configuring your appliance can be found on the rating plate on the rear of the appliance. The gas type set at the factory is marked with an asterisk (*).
- After converting the appliance from one gas type to another, the new gas type must be labelled on the rating plate.
 - Use the gas conversion label to do this.
 - (*) is used to indicate the gas type on the label.
 - Stick the label on which the gas conversion is marked with a star (*) in the designated location on the rating plate.
- The changes made to the appliance and the type of connection are essential to enabling the appliance to work safely and in accordance with the relevant regulations.
- Switch off the power supply and gas supply before carrying out any work.
- After working on the gas connection, always check that the connection is not leaking. The manufacturer accepts no responsibility for a gas leak at a manipulated gas connection.

WARNING – Risk of explosion!

A gas leak could occur.

If you move the appliance after the gas supply has been established, a gas leak could occur.

- ▶ Do not move the appliance once the gas supply is connected.
- ▶ If you move the appliance, check that the connections are not leaking.

ATTENTION

Do not hold and move the appliance at the gas pipe (collector). Damage to the gas pipe may lead to gas leak. The gas pipe is not designed for the weight of the appliance.

- ▶ Do not hold and move the appliance at the gas pipe.

23.2 Appliance information

Enter the factory settings for the gas type and gas pressure in the table below and then add the applicable gas

type and gas pressure settings for once conversion has been carried out.

E no.	FD
After-sales service telephone number	
Type of gas/gas pressure	The data can be found on the rating plate.
Type of gas/gas pressure	Data following gas conversion

23.3 Selecting the gas connection side

On many appliances, you can carry out the gas connection on the right- or left-hand side. If necessary, you can change the connection side.

Requirements

- Shut off the main gas line.
 - Seal the gas connecting piece on the side that is not being used with a blind plug.
1. Place the new seal in the blind plug. Ensure that the seal is seated correctly.
 2. **Note:** Use a torque wrench when connecting the appliance. Secure the gas connecting piece to the appliance **using a 22 mm spanner** and place the blind plug onto the connecting piece using a 24 mm spanner.

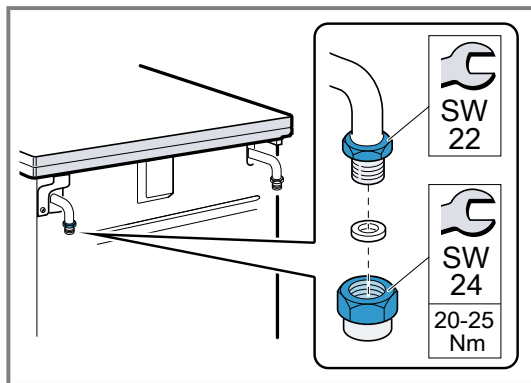

3. After changing the connection side, carry out a leak test. You can find additional information about this in the section entitled "Leak and function test" → Page 38.

23.4 Gas connection

These instructions apply only if the appliance is installed in countries that are specified on the rating plate. If the appliance is installed and used in a country that is not specified on the rating plate, add installation and assembly instructions that contain the necessary information for the connection conditions for the appliance in the respective country.

Note: Use a torque wrench when connecting the appliance.

Natural gas connection (NG)

If you are using natural gas (NG), the gas supply should be connected via a gas pipe or a safety gas hose with threaded fittings at both ends.

Connection types:

- *G $\frac{1}{2}$: EN ISO 228 G $\frac{1}{2}$ (TS EN ISO 228 G $\frac{1}{2}$)
- *R $\frac{1}{2}$: EN 10226 R $\frac{1}{2}$ (TS 61-210 EN 10226 R $\frac{1}{2}$)

⚠ WARNING – Risk of explosion!

A gas leak may occur due to a damaged connection nozzle.

- ▶ When connecting the gas pipe or safety gas hose, never tighten the gas connecting piece on the appliance using a 22 mm spanner. This may damage the connecting piece.

Natural gas connection (NG)

1. Insert the new seal in the connecting piece. Ensure that the seal is seated correctly.
2. Secure the gas connecting piece to the appliance **using a 22 mm spanner** and place the connecting piece into the connecting piece using a 24 mm spanner.

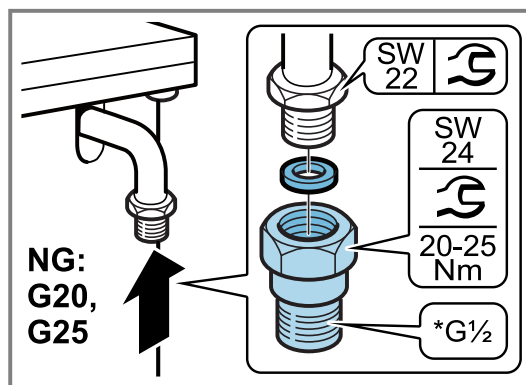

3. Place the new seal into the gas pipe or safety gas hose. Ensure that the seal is seated correctly.
4. Secure the connecting piece using a **24 mm spanner**. Use a 24 mm spanner to place the threaded fitting of the gas pipe or safety gas hose on the connecting piece and tighten it firmly.

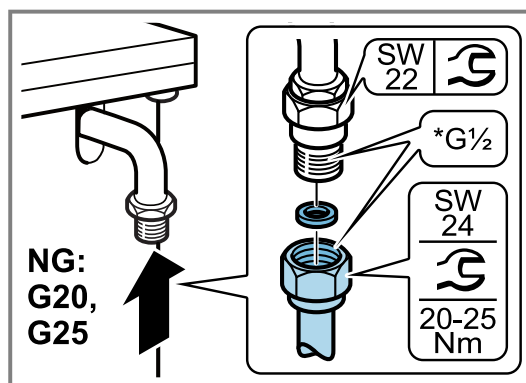

5. Open the gas connection shut-off. Carry out a leak test → Page 38.

Natural gas connection (NG)

1. Insert the new seal in the connecting piece. Ensure that the seal is seated correctly.

2. Secure the gas connecting piece to the appliance **using a 22 mm spanner** and place the connecting piece into the connecting piece using a 24 mm spanner.

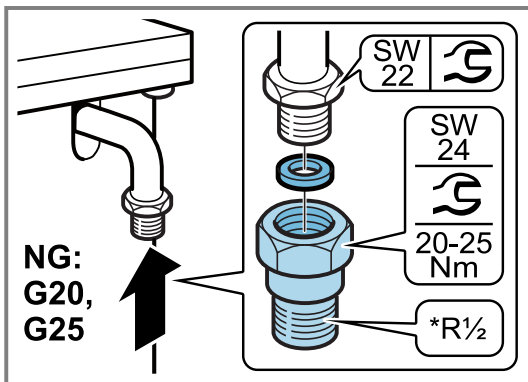

3. Secure the connecting piece using a **24 mm spanner**. Use a 24 mm spanner to place the threaded fitting of the gas pipe or safety gas hose on the connecting piece and tighten it firmly.

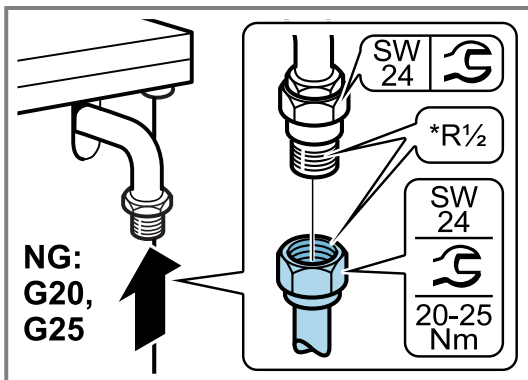

4. Open the gas connection shut-off. Carry out a leak test → *Page 38*.

Liquefied gas connection (LPG)

If you use liquefied gas (LPG), establish the gas connection via a gas hose or a fixed connection.

Observe the specific guidelines for each country.

If you are using a gas hose, observe the following:

- Use a safety gas hose or a plastic gas hose with a diameter of 8 or 10 mm.
- Secure the hose to the gas connection using an approved connecting device, e.g. a hose clamp.
- The hose must be short and completely leak-tight. The hose must not be longer than 1.5 m. Observe the applicable guidelines.
- Replace the gas hose once a year.

Connection with the gas hose

1. Insert the new seal in the connecting piece. Ensure that the seal is seated correctly.

2. Secure the gas connecting piece to the appliance **using a 22 mm spanner** and place the connecting piece into the connecting piece using a 24 mm spanner.

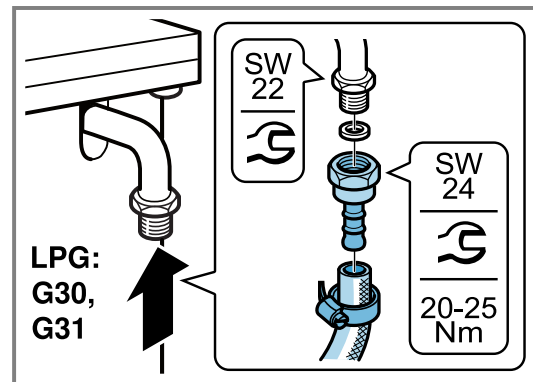

3. Fit the safety gas hose and use a pipe union or cable clamp to tighten it securely.

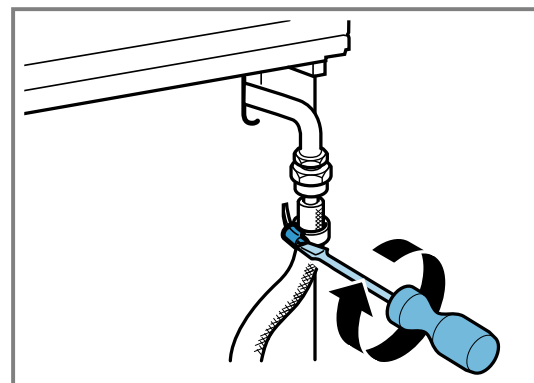

4. Open the gas connection shut-off. Carry out a leak test → *Page 38*.

23.5 Converting the gas type

You can convert the type of gas that has been set for the appliance.

Note: You can find more information about which gas types can be used with the appliance and the appropriate gas nozzles in the section entitled "Technical data – Gas" → *Page 39*. The numbers on the burners refer to their diameter.

Converting the gas type

- Replacing the gas connection part.
- Replace the burner nozzles.
- Depending on the gas setting that is configured at the factory, replace or tighten the bypass nozzles of the burner taps.

After conversion

- Always test for leaks after converting the appliance to a different gas type. You can find additional information about this in the section entitled "Leak and function test" → *Page 38*.
- The burning behaviour must be checked after the product has been converted to a different gas type. You can find additional information about this in the section entitled "Checking the correct burner behaviour" → *Page 39*.
- Enter the newly set type of gas and gas pressure in the table. You can find additional information about

this in the section entitled "Appliance information" → Page 33.

ATTENTION

After converting the type of gas, label the type of gas that is now set.

- ▶ After converting the type of gas, **affix** the label with the specification of the gas type and the star shape at the designated location on the appliance's rating plate.







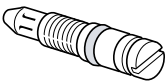

Parts for the gas conversion

The parts that you need for the gas conversion procedure described here are listed below.

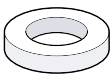
Note

The accessories supplied may differ depending on the appliance model.

- The gas connecting piece may vary depending on the gas type and the country-specific regulations.
- In the "Technical data – Gas" → Page 39 table, determine the correct nozzle diameter.
- Always use a new seal.
- (*) Never establish a gas connection without these parts.

	Explanation
	Bypass nozzle
	Burner nozzle
	(*) Seal
	(*) Connecting piece for natural gas (NG: G20, G25) <ul style="list-style-type: none"> ▪ TS 61-210 EN 10226 R½ ▪ EN 10226 R½
	(*) Connecting piece for natural gas (NG: G20, G25) <ul style="list-style-type: none"> ▪ TS EN ISO 228 G½ ▪ EN ISO 228 G½
	(*) Connecting piece for liquefied gas (LPG: G30, G31)
	Connecting piece
	Blind plugs (closure part)

Replacing the cooker burner nozzles

1. Switch off all of the knobs on the control panel.
2. Close the gas connection shut-off.
3. Remove the pan support grids or the pan support racks and the burner parts.

4. Use the socket wrench 7 to remove the cooker burner nozzles.

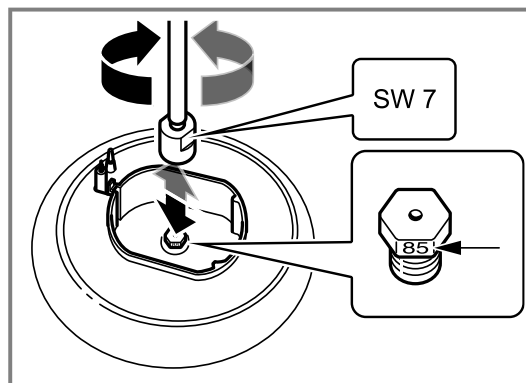

5. Look up the burner nozzles in the table. You can find additional information about this in the section entitled "Technical data – Gas" → Page 39.
 - ▶ Fit the new nozzles into the appropriate burners.
6. After replacing the nozzles, check that there are no leaks. You can find additional information about this in the section entitled "Leak and function test" → Page 38.

Adjusting or replacing bypass nozzles (small flame setting)

You can set the minimum flame height for the burners via the bypass nozzles.

Requirements

- Close the gas isolating equipment.
 - Disconnect the appliance from the power supply.
1. Switch off all of the knobs on the control panel.
 2. Remove the knobs one by one by holding them tightly against the control panel and pulling them towards you slightly.

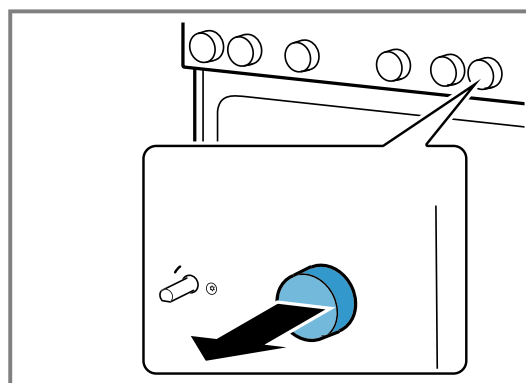

Converting the appliance from natural gas to liquefied gas

If the appliance was set to natural gas at the time of delivery (factory setting) (NG: G20, G25) and is now being converted to liquefied gas for the first time (LPG: G30, G31):

1. In order to gain access to the bypass nozzles, remove the control panel. You can find additional information about this in the section entitled "Removing the control panel" → Page 37.
2. Tighten the bypass nozzles as far as it will go.
3. Then carry out the steps described in the section entitled "Installing the control panel" → Page 38.

Converting the appliance from liquid gas to natural gas

If you convert the appliance from liquefied gas (LPG: G30, G31) to natural gas (NG: G20, G25) or if you already carried out this conversion and then undo this:

1. Replace all of the bypass nozzles in the appliance. You can find additional information about this in the section entitled "Removing the control panel" → Page 37.
2. Then carry out the steps in the section entitled "Replacing the bypass nozzles" → Page 38.
3. Then carry out the steps described in the section entitled "Installing the control panel" → Page 38.

Removing the control panel

1. Remove the pan support grids or the pan support racks and the burner parts.

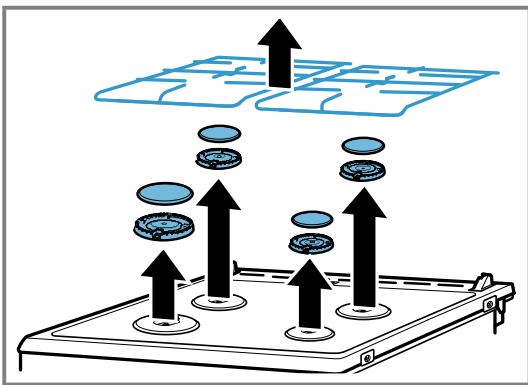

2. If burner connection screws are present on the hob, remove all of these.

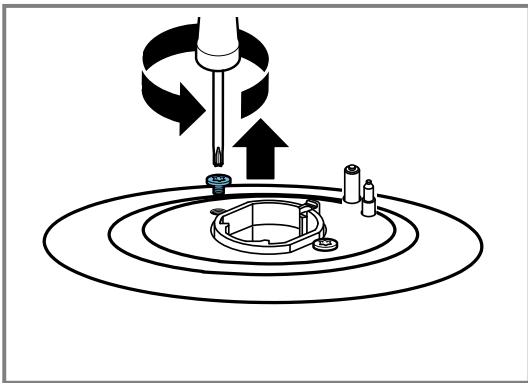

3. Remove the two screws (T20) at the front right and left of the hob panel. Do not remove the plastic parts that are located below these.

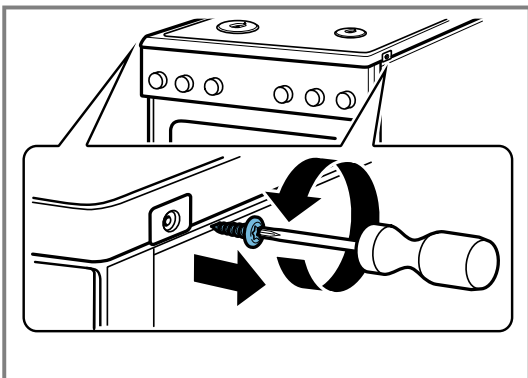

4. **Note:** To ensure that no scratches are formed on the matte glass plate, do not allow the underside of the hob to come into contact with objects. Hold the front section of the hob and tilt it upwards at a maximum angle of 30°. Secure the hob with the profile bar by placing it vertically on the front burner mount.

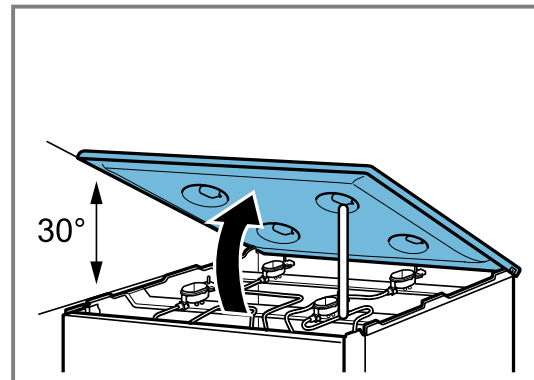

5. Remove the plastic covers from the front profiles on the right and left. Ensure that the covers are not damaged or scratched. Unscrew the screws (T20) below these.

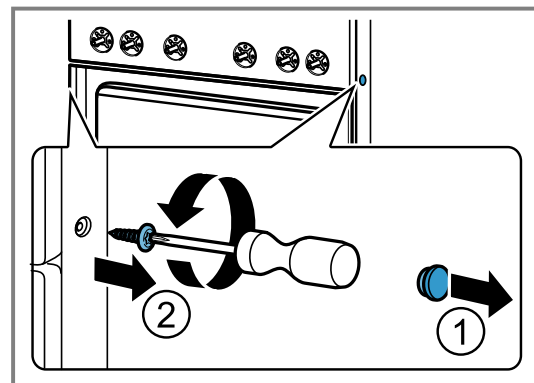

6. **Note:** Remove the screws that are mentioned below so that the switch and the electronic parts are not damaged. Remove the four screws (M4) that are uncovered when you remove the control knobs (T15) from the control panel.

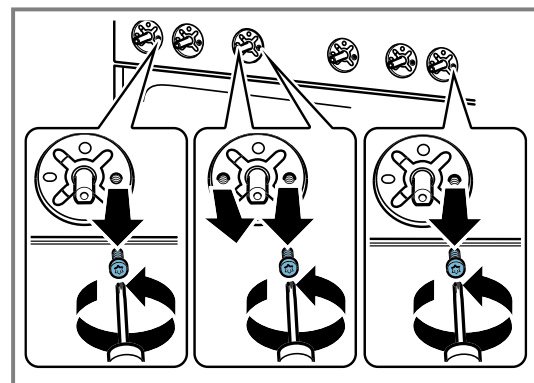

7. **Note:** In order to access the bypass nozzles on the right-hand side, turn the control panel clockwise slightly. In order to access the bypass nozzles on the left side, turn the control panel anti-clockwise slightly. Ensure that the cables are not damaged and the connections do not come loose.

Grip the panel with both hands and slowly pull it upwards. Remove the panel from the fastening lugs. Then carefully pull the panel forwards to remove it. Ensure that the cables are not damaged and that the connections do not come loose.

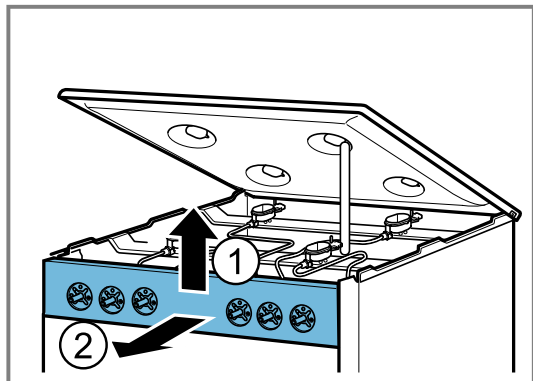

Replacing bypass nozzles

1. Use a flat-head screwdriver (no. 2) to unscrew the bypass nozzles. Remove the bypass nozzles.

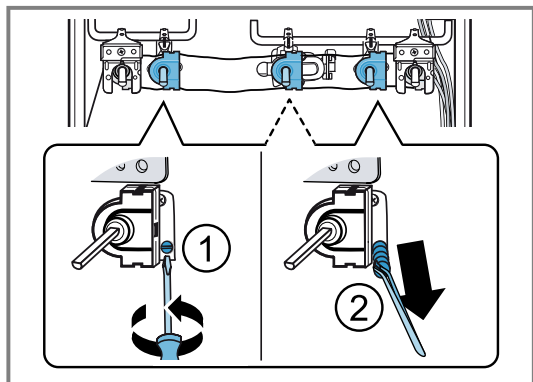

2. Select the appropriate replacement bypass nozzles from the table. You can find additional information about this in the section entitled "Technical data – Gas" → Page 39.
3. Check that the seals on the bypass nozzles are seated correctly and work properly. Only use bypass nozzles with absolutely faultless seals.

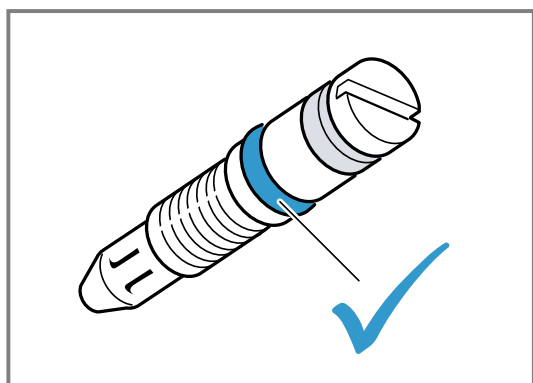

4. Insert the new bypass nozzles and tighten them securely. Ensure that all bypass nozzles have been fastened to the correct taps.
5. At this stage, it is important to test for leaks. You can find additional information about this in the section entitled "Leak and function test" → Page 38.

Fitting the control panel

To reassemble, proceed in the reverse order of disassembly.

1. Take hold of the front panel with both hands and carefully fit it into place. Ensure that the cables are not damaged and the connections do not come loose. Lower it slightly and insert it into the front panel.
2. Insert the screws (T15) (M4) that were removed from the control panel.
3. Insert and tighten the screws (T20) that were removed from the front profiles on the right and left. Attach the plastic covers.
4. Carefully install the hob. Ensure that the plastic parts which must remain underneath the screws do not fall out. Unscrew the two screws (T20) on the front left and right on the hob. If there are any burner connection screws, screw them all into the cooktop.
5. Install the burner bases in their respective positions according to their size. Make sure that the ignition plugs are placed in the appropriate openings next to the burner bases. Place the enamelled burner lids onto the centre of the appropriate lower parts of the burner and, in doing so, note the sizes.
 - ▶ Fit the pan support grids and the pan support racks. Ensure that the 80 mm pan support is fitted on the auxiliary burner.
6. Carefully insert the knobs.
 - ▶ At this stage, it is important to check that the gas burners are burning correctly. You can find additional information about this in the section entitled "Checking the correct burner behaviour" → Page 39.
7. Check whether the appliance is working correctly.

23.6 Leak test and function test

The leak test must be carried out by two people.

⚠ WARNING – Risk of explosion!

Sparks, flames or open flames may cause explosions during the leak and function test.

- ▶ Ensure that no sparks are produced.
- ▶ Do not use any fire or naked flames.
- ▶ Only check the leak tightness using a suitable foam.

Gas leak

- Close the gas connection locking device.
- Ventilate the relevant location sufficiently.
- Check the gas and nozzle connections once more.
- Repeat the leak test → Page 38.

Checking the gas connection

1. Open the gas connection shut-off.
2. Apply suitable foam around the gas connection.
 - ✓ If dispersions and bubbles occur on the foamy surface and these indicate that gas is escaping, follow the instructions in the section entitled "What to do if there is a gas leak" → Page 38.
3. Follow the same instructions for the part that is sealed with the blind plug.

Checking the cooker burner nozzles

Check the leak tightness of each nozzle.

1. Open the gas connection shut-off.

2. To check, carefully cover the hole in the burner nozzle with your finger or a special device.
 3. Apply suitable foam around the nozzle.
 4. Press on the burner knob and turn the knob anti-clockwise. Gas therefore comes to the nozzle.
- ✓ If dispersions and bubbles occur on the foamy surface and these indicate that gas is escaping, follow the instructions in the section entitled "What to do if there is a gas leak" → Page 38.

Checking the bypass nozzles

Check the leak tightness of each bypass nozzle.

1. Open the gas connection shut-off.
 2. To check, carefully cover the hole in the burner nozzle with your finger or a special device.
 3. Apply suitable foam around the bypass nozzle on the burner that is to be checked.
 4. Press on the tap spindle and turn it anti-clockwise. Gas therefore comes to the nozzle.
- ✓ If dispersions and bubbles occur on the foamy surface and these indicate that gas is escaping, follow the instructions in the section entitled "What to do if there is a gas leak" → Page 38.

23.7 Checking the correct burner behaviour

Check the burning and soot formation of each burner after the product has been converted to a different gas type. If there is a problem, compare the nozzle values with the values in the table.

Checking the correct burner behaviour of the cover burner

1. Ignite the gas cooker burners in accordance with the instructions in the operating manual.
→ "Operating the hotplate", Page 16
 2. Set the gas cooker knob to the small flame setting. Check whether the flame safety system is working by keeping the flame at the "small flame" setting for one minute.
 3. Check that the burners are burning correctly with both large and small flames.
- ✓ The flame must burn evenly and steadily.
4. Turn the burner knob back and forth quickly between the large flame setting and the small flame setting. Repeat this process several times.
- ✓ The gas flame must not flicker or go out.

23.8 Technical data – Gas

The different types of gas and the corresponding values are listed.

Information on some types of gas

Note the following information for the gas types that are listed in the table for some burners.

Type of gas	Explanation
G20/25 (20/25 mbar)	For France and Belgium
G2.350 (13 mbar)	For Poland
G30 (50 mbar)	The after-sales service must order the nozzle set HEZ353110.

Nozzle values for the auxiliary burner

Note the following information for the gas types that are listed in the table for some burners.

	G20/ G25	G20	G20	G25	G25	G25.3	G30/ G31	G30	G30	G27	G2.350
Gas pressure (mbar)	20/25	20	25	20	25	25	28– 30/37	50	37	20	13
Nozzle (mm)	0.72	0.72	0.68	0.77	0.72	0.72	0.50	0.43	0.47	0.77	1.00
Bypass nozzle ¹ (mm)	0.52/0. 5	0.52/0 .5	0.52/0 .5	0.52/0 .5	0.52/0 5	0.52/0 .5	0.32/0 .3	0.32/0 .3	0.32/0 .3	0.52/0 .5	0.52/0. 5
Max. input power (kW)	1	1	1	1	1	1	1	1	1	1	1
Min. input power (kW)	≤0.55	≤0.55	≤0.55	≤0.55	≤0.55	≤0.55	≤0.55	≤0.55	≤0.55	≤0.55	≤0.55
Gas flow at 15 °C and 1013 mbar m ³ /h	0.095/ 0.111	0.095	0.095	0.111	0.111	0.108	-	-	-	0.116	0.132
Gas flow at 15 °C and 1013 mbar g/h	-	-	-	-	-	-	73/71	73	73	-	-

Nozzle values for the standard-output burner

Note the following information for the gas types that are listed in the table for some burners.

	G20/ G25	G20	G20	G25	G25	G25.3	G30/G31	G30	G30	G27	G2.350
Gas pressure (mbar)	20/25	20	25	20	25	25	28– 30/37	50	37	20	13
Nozzle (mm)	0.97	0.97	0.91	1	0.94	0.94	0.65	0.58	0.62	1	1.31

¹ Use the bypass nozzle with the appropriate diameter that is included in the set.

	G20/ G25	G20	G20	G25	G25	G25.3	G30/G31	G30	G30	G27	G2.350
Bypass nozzle ¹ (mm)	0.6/0.5 8	0.6/0. 58	0.6/0. 58	0.6/0. 58	0.6/0. 58	0.6/0. 58	0.4/0.38	0.4/0. 38	0.4/0. 38	0.6/0. 58	0.6/0.5 8
Max. input power (kW)	1.75	1.75	1.75	1.75	1.75	1.75	1.75	1.75	1.75	1.75	1.75
Min. input power (kW)	≤0.9	≤0.9	≤0.9	≤0.9	≤0.9	≤0.9	≤0.9	≤0.9	≤0.9	≤0.9	≤0.9
Gas flow at 15 °C and 1013 mbar m ³ /h	0.167/ 0.194	0.167	0.167	0.194	0.194	0.190	-	-	-	0.203	0.225
Gas flow at 15 °C and 1013 mbar g/h	-	-	-	-	-	-	127/125	127	127	-	-

Nozzle values for the high-output burner

Note the following information for the gas types that are listed in the table for some burners.

	G20/ G25	G20	G20	G25	G25	G25.3	G30/ G31	G30	G30	G27	G2.350
Gas pressure (mbar)	20/25	20	25	20	25	25	28– 30/37	50	37	20	13
Nozzle (mm)	1.16	1.16	1.10	1.34	1.26	1.26	0.85	0.75	0.80	1.38	1.65
Bypass nozzle ¹ (mm)	0.78/0. 75	0.78/0 .75	0.78/0 .75	0.78/0 .75	0.78/0 .75	0.78/0 .75	0.49/0. 46	0.49/0 .46	0.49/0 .46	0.78/0 .75	0.78/0. 75
Max. input power (kW)	3	3	3	3	3	3	3	3	3	3	3
Min. input power (kW)	≤1.3	≤1.3	≤1.3	≤1.3	≤1.3	≤1.3	≤1.3	≤1.3	≤1.3	≤1.3	≤1.3
Gas flow at 15 °C and 1013 mbar m ³ /h	0.285/ 0.332	0.285	0.285	0.332	0.332	0.325	-	-	-	0.348	0.397
Gas flow at 15 °C and 1013 mbar g/h	-	-	-	-	-	-	218/21 4	218	218	-	-

¹ Use the bypass nozzle with the appropriate diameter that is included in the set.



Many thanks for choosing a Bosch home appliance!

Register your new appliance now on MyBosch and benefit directly from:

- **Expert advice and tips to make the most of your appliance**
- **Options for warranty extension**
- **Discounts on spare parts and accessories**
- **Digital information for use and all appliance data to hand**
- **Easy access to Bosch Home Appliance Service**

Simple to register, free of charge – including on mobile devices:

www.bosch-home.com/welcome



Need some help? You can find it here.

Expert advice on your Bosch home appliances, help with problems or repairs by professionals from Bosch.

Discover all the different ways Bosch can assist you:

www.bosch-home.com/service

The contact details of all countries are listed in the attached service directory.

BSH Hausgeräte GmbH

Carl-Wery-Straße 34
81739 München, GERMANY
www.bosch-home.com

A Bosch Company



9001946724 (060226) REG25

en