

CIRCUS

ELICA DESIGN CENTER



WALL

TECHNICAL FEATURES INFORMATIONS TECHNIQUES

Size Dimensions	60 - 90 cm
Version Version	Duct-out Extraction
Finish Finition	Stainless steel + glass Acier inox + verre

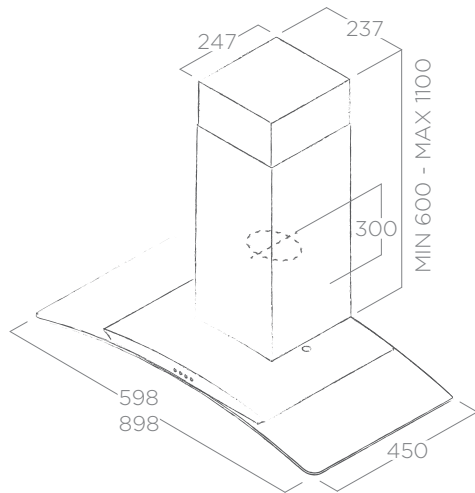

ECLAIRAGE LIGHTING

Type Type	LED 2 x 2,5 W
Intensity Intensité	141 LUX
Temperature Température	3500 K

PERFORMANCE PERFORMANCE

Controls Commandes	3s Mechanical Push Button Clavier Mécanique 3V	(*) 3s Mechanical Push Button Clavier Mécanique 3V
Min - max airflow Débit d'air min - max	250 - 550 m ³ /h	300 - 800 m ³ /h
Min - max noise level Niveau sonore min - max	55 - 62 db(A)	44 - 67 db(A)
Total absorption Absorption totale	140 W	185 W
Duct size Sortie	150 mm	150 mm
Grease aluminium Filter included Filtre à graisse en aluminium inclus		

ACCESSORIES ACCESSOIRES

Charcoal Filter Filtre à charbon	CFC0141529
Long life filter Filtre longue durée	CFC0141725

MODELS MODÈLES

CIRCUS IX/A/60	68116393A
CIRCUS IX/A/90	68116392A
CIRCUS IX/F/90/PB (*)	PRF0113138A

